

LABOUR PUMP UPGRADES

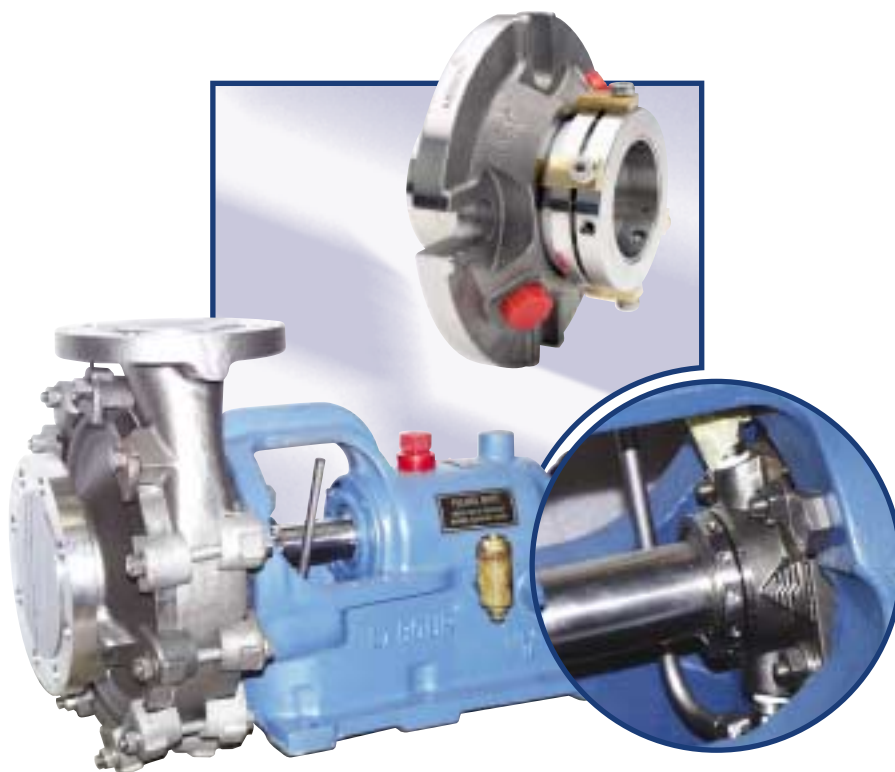

- SHAFT ARRANGEMENT UPGRADED IN LINE WITH ISO 5199
- NEW AND IMPROVED 'BACK' TO INCLUDE LATEST SEAL TECHNOLOGY
- IMPROVED CASING GASKET TECHNOLOGY
- PRE-ENGINEERED BEARING SEALS OPTION (MAGTECTA™)
- FULLY COMPLIANT AND CERTIFIED TO ATEX
- INCREASED MEAN TIME BETWEEN FAILURE
- GENUINE AND ORIGINAL OEM PARTS
- ALL WORK CERTIFIED TO ISO 9001

LABOUR PUMP UPGRADES - all cartridge seals can be used

BEFORE - original design

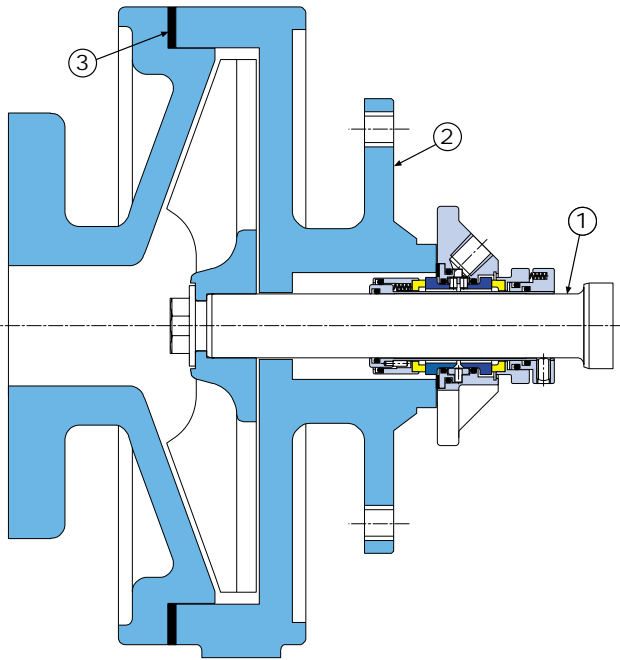

Weaknesses

- ① Stiffness ratio (thin shaft, long overhang).
- ② Conventional stuffing box.
- ③ Poor clamping arrangements creating blow-out.

AFTER - upgraded design

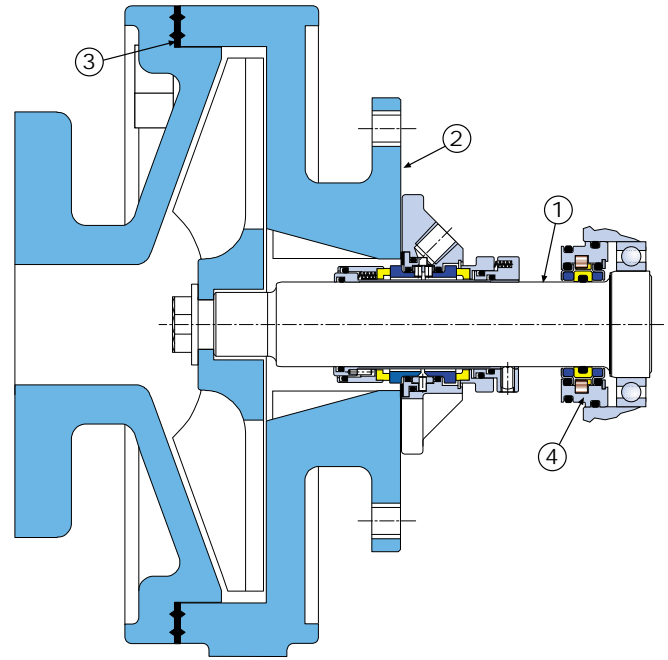

Strengths

- ① Improved shaft design (thicker, 'stiffer').
- ② New back to include seal chamber for single / dual cartridge designs.
- ③ New 'cast' clamp arrangement for improved sealing.
- ④ MagTecta™ bearing seals included.

Fits the following

Pump Type	Size	Pump Type	Size
10 DZTM	33mm	15 DZTM	35mm
12 DZTM	33mm	20 DZTM	38mm
14 DZTM	33mm	30 DZTM	43mm

THIS DOCUMENT IS DESIGNED TO PROVIDE DIMENSIONAL INFORMATION AND AN INDICATION OF AVAILABILITY. FOR FURTHER INFORMATION AND SAFE OPERATING LIMITS CONTACT OUR TECHNICAL SPECIALISTS AT THE LOCATIONS BELOW.



USE DOUBLE MECHANICAL SEALS WITH HAZARDOUS PRODUCTS. ALWAYS TAKE SAFETY PRECAUTIONS:

- GUARD YOUR EQUIPMENT
- WEAR PROTECTIVE CLOTHING



WARNING

AESSEAL plc
Mill Close
Templeborough
Rotherham
S60 1BZ
United Kingdom
Telephone:
Fax:
E-mail:
Internet:



INVESTOR IN PEOPLE
+44 (0) 1709 369966
+44 (0) 1709 720788
seals@aes seal.com
<http://www.aes seal.com>

Distributed by:

UK Sales & Technical advice:
AESSEAL Pump Centre
25 - 26 Stapledon Road
Orton Southgate
Peterborough
PE2 6TD
Telephone: 01733 230787
Fax: 01733 230788

ALL SIZES ARE SUBJECT TO MANUFACTURING TOLERANCES. WE RESERVE THE RIGHT TO MODIFY SPECIFICATIONS AT ANY TIME.