

T.A.C. SERIES

THOMSON ADVANCED CARTRIDGE

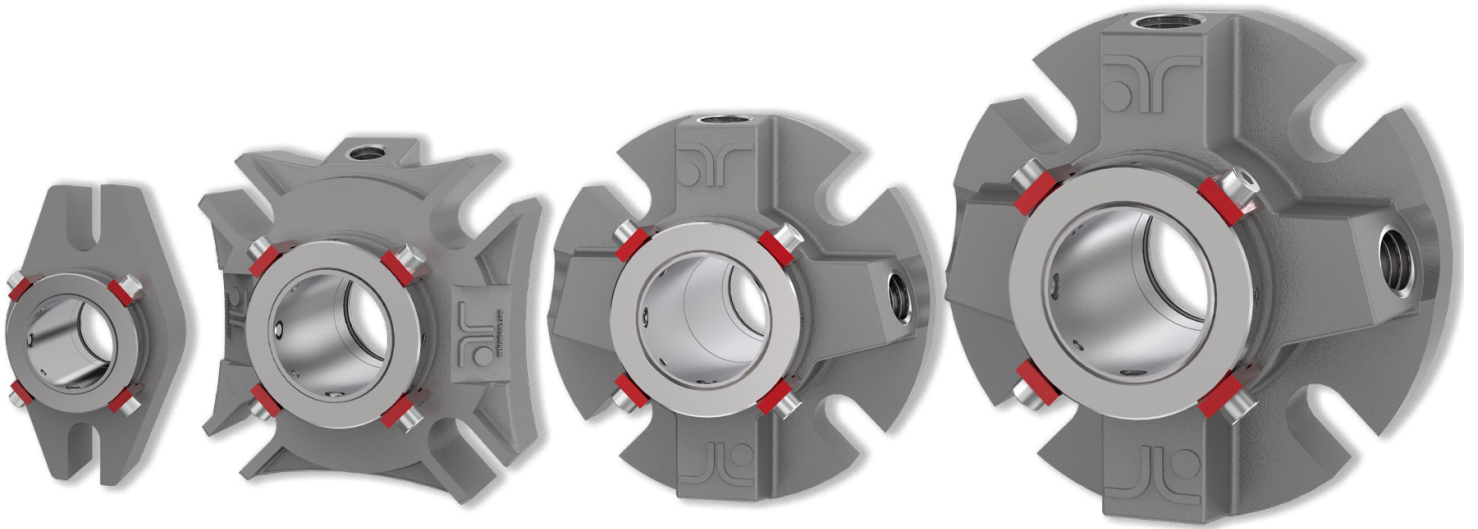

A FULL RANGE OF UNIVERSAL
CARTRIDGE MECHANICAL SEALS

T.A.C. SERIES

TAC Mechanical Seals

The Thomson Advanced Cartridge seal (TAC) is a family of mechanical seals designed for maximum versatility, increased reliability and plant-wide standardization. TAC seals are engineered to fit virtually all centrifugal ANSI pump makes and models from manufacturers around the globe. All TAC seals feature interchangeable internal parts which are designed to withstand the most extreme conditions. TAC seals incorporate the latest sealing technology, making them ideal for a variety of duties ranging from aggressive chemicals to abrasive slurries. The TAC seal is a true all-in-one for general service.

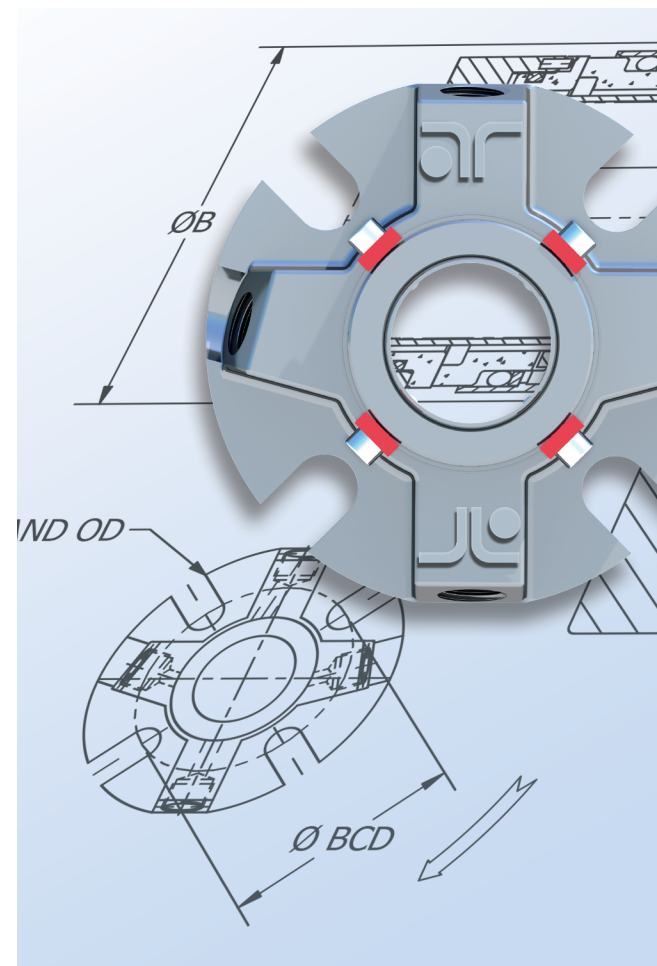

50 Year Pedigree

For over half a century, the AR Thomson Group has specialized in fluid sealing solutions including mechanical seal service and repair. During this time, we have been challenged with some of the most extreme and demanding seal applications found in the industry. The knowledge we have gained from this experience, and the feedback from our customers, has culminated in the Thomson Advanced Cartridge seal family. The advanced features of the TAC seal act together to improve the reliability of your rotating equipment. Some key examples:

TAC Thermal Management System

Heat build up is the number one threat to mechanical seal longevity. The TAC seal family has powerful defense measures to combat this threat:

- Pumping Ring - Maximizes barrier fluid flow in the dual arrangement.
- Heat Transfer Ring - Greatly increases heat transfer away from the faces out to the process.
- Oversized Flush Ports - Increases barrier fluid flow in the dual arrangement.

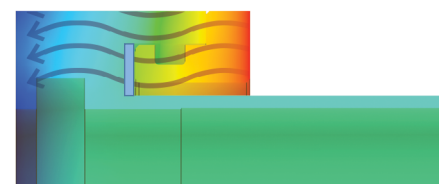

Heat conductivity with transfer ring



Heat build up at face with without heat transfer ring

Modern Design

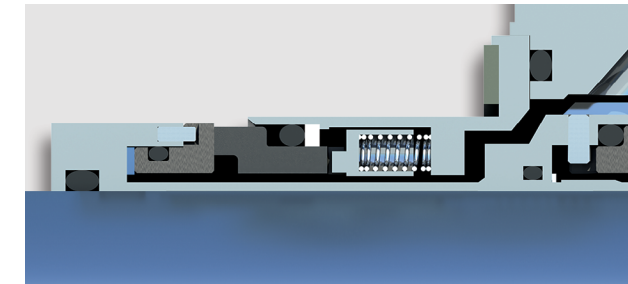

Monolithic faces prevent deformation in extreme conditions which increases reliability.

TAC seals incorporate the latest technology to increase reliability and dependability:

- Monolithic Seal Faces - Ensures face stability in extreme conditions.
- Stationary Springs - Self-aligning faces.
- Hardened Drive Screws - Ensures a secure, positive drive.
- Superior Gland Seal - Universal Eclipse 7576 gasket.

Customizable

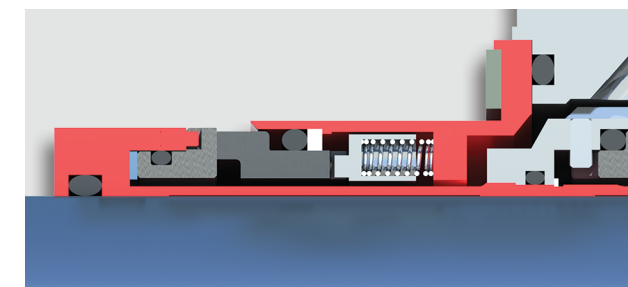

Bi-Metallic TAC 44 with exotic alloy wetted parts.

The TAC Seal can be sourced in a multitude of material combinations including bi-metallic and full exotic alloys such as:

- Alloy 20
- Hastelloy C
- Titanium
- CD4MCu

Advanced Face Material Range

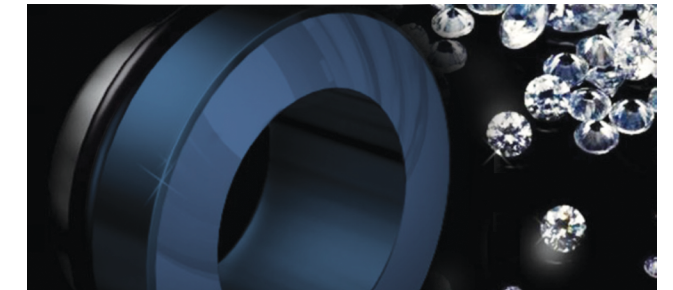

- Silicon Carbide
- Tungsten Carbide
- CVD Diamond Coated
- Graphitized Carbon

Retrofits Virtually All Pumps

Compact design for maximum versatility. Retrofits most centrifugal pumps such as:

- Goulds
- Durco
- Worthington
- IDP
- Taco
- A-C
- Hayward-Gordon
- Cornell
- Canada Pump
- Moyno
- Nash
- Viking
- Weir
- Wemco

T.A.C. SERIES

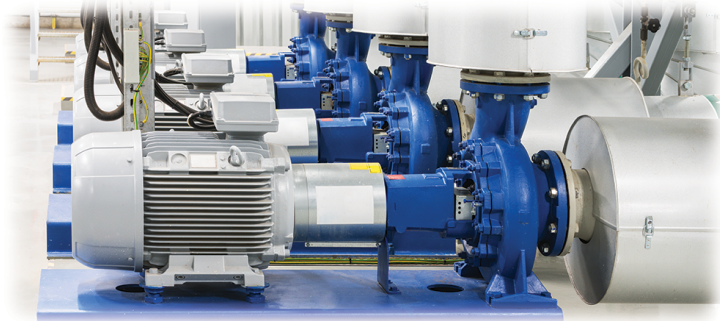

TAC 33 - Premium Single Cartridge Seal

The TAC-33 is a premium single cartridge seal that has the same rugged internals as the TAC-44 along with quench containment device and heat management features.



TAC 44 - Premium Dual Cartridge Seal

The TAC-44 is a premium dual seal in the TAC line-up. With many advanced features supplied as standard, the TAC 44 is extremely reliable and highly versatile.

KEY FEATURES AND ADVANTAGES:

1. Heat Transfer Ring: Conducts face-generated heat away from the seal.
2. Superior Gland Gasket: Eclipse 7576 with Universal chemical compatibility.
3. Monolithic Faces: Ensures face stability in extreme conditions.
4. Heavy Duty 316SS Gland: Eliminates distortion and uneven loading.
5. Tangential Ports: Bi-directional flush.
6. Stationary Springs: Isolated from process and allows faces to self-align.
7. Close Tolerance Bushing: For containing process media or adding quench and drain.
8. Hardened Set Screws: For a secure, positive drive.

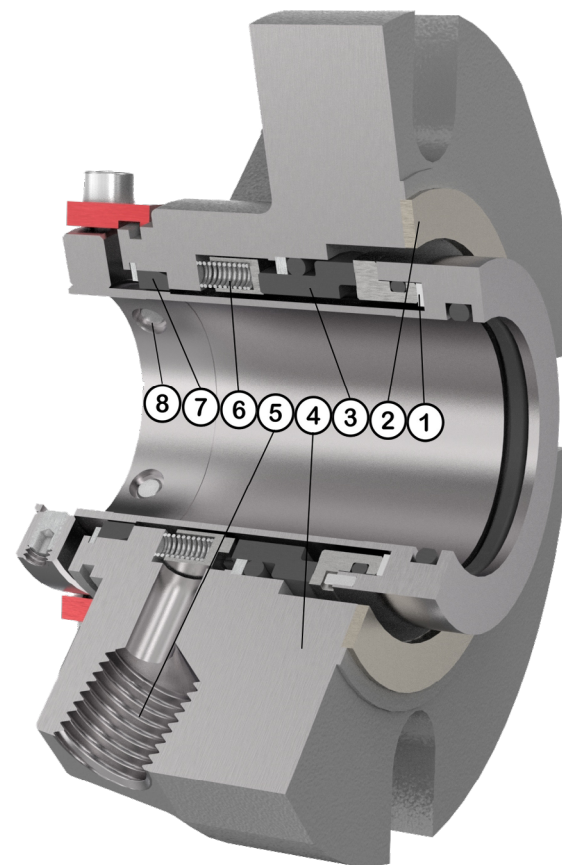

KEY FEATURES AND ADVANTAGES:

1. Heat Transfer Ring: Conducts face-generated heat away from the seal.
2. Monolithic Faces: Ensures face stability in extreme conditions.
3. Stationary Springs: Isolated from the process and allow faces to self-align.
4. Superior Gland Gasket: Eclipse 7576 with universal chemical compatibility.
5. Integral Pumping Ring: Greatly increases barrier circulation rate.
6. Oversized Ports: Maximizes barrier fluid exchange.
7. Tangential Flush Ports: Bi-Directional shaft rotation.
8. Heavy Duty 316SS Gland: Prevents distortion and uneven loading.
9. Hardened Set Screws: For a secure, positive drive.
10. Bi-Metallic and Full Exotic Alloy Available: Can be supplied in exotic alloys for severe chemical and abrasive service.

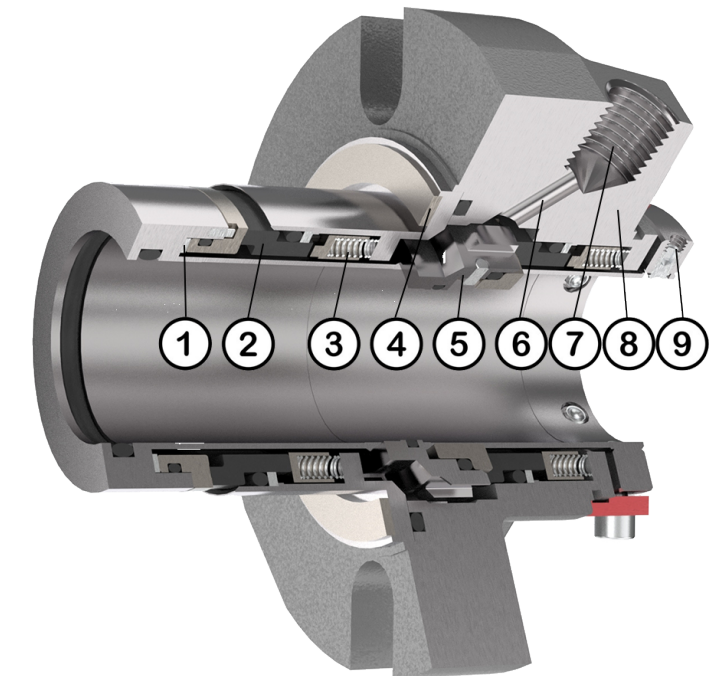

T.A.C. SERIES

TAC Seal Series

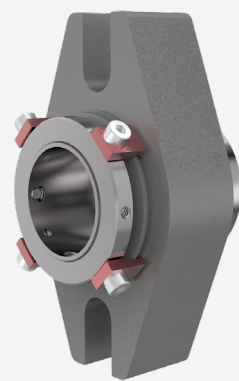

TAC 11

Single Cartridge with Elliptical Gland

The TAC 11 is a single, stationary spring cartridge seal with an Elliptical gland. This is an economical crossover seal that is intended to replace packing or component seals.

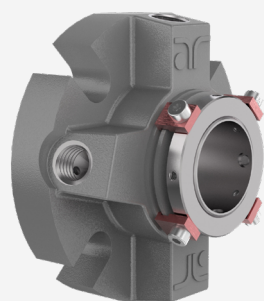

TAC 33

Single Cartridge Seal with Quench

The TAC 33 is a single cartridge seal with premium features including tangential flush ports, quench and drain ports, carbon restriction bushing or quench containment device. The TAC 33 is available in a full range of exotic alloy materials.

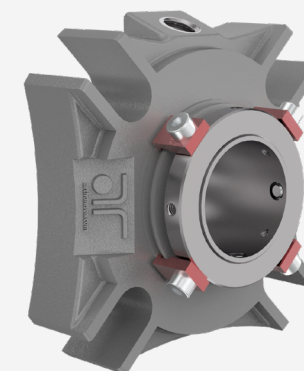

TAC 20

Single Cartridge with Flush

The TAC 20 is a single, stationary spring seal with flush port. It is an economical compact seal with basic environmental control capability.

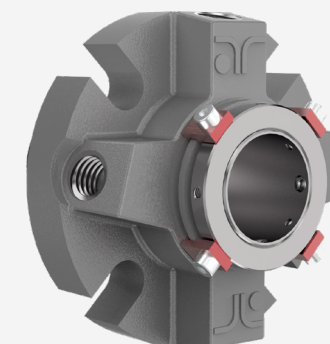

TAC 44

Premium Dual Cartridge Seal

The TAC 44 is a premium dual seal with a heat management system, monolithic faces, bi-directional flush ports and self-aligning faces. The TAC 44 is available in virtually any metallurgy or face combination, making it an extremely versatile seal.

T.A.C. SERIES

TAC 33

TAC 33 - Standard Dimensions

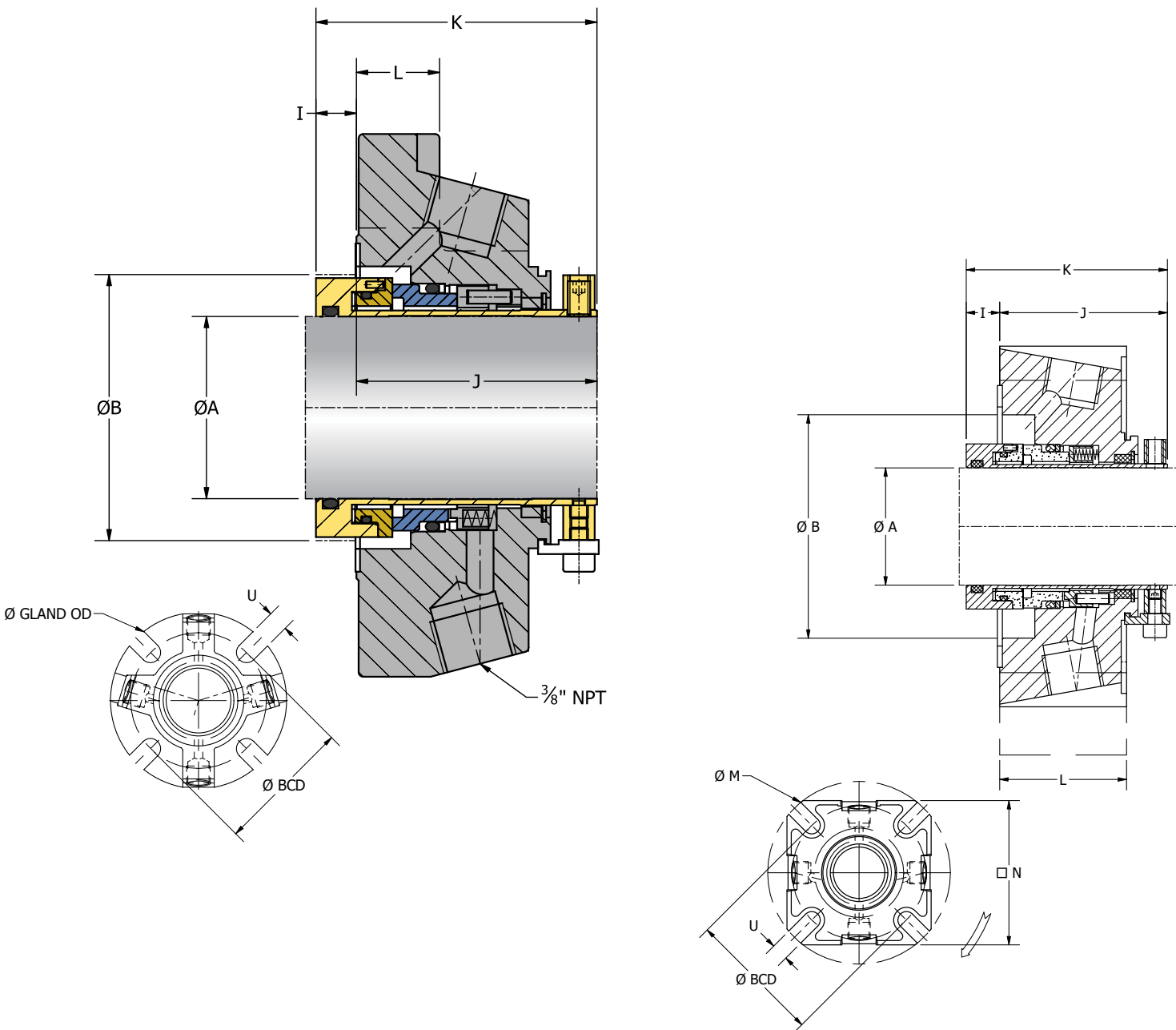

Shaft Diameter	Box Bore		IB	OB	OAL	L	Gland Diameter	BCD		Bolt Slot
	Min	Max						Min	Max	
A	B	B	I	J	K	L	Gland OD			U
1.000	1.626	1.973	0.346	1.953	2.299	0.587	3.882	2.803	3.362	0.520
1.125	1.752	2.057	0.390	1.976	2.366	0.756	4.008	2.929	3.488	0.520
1.250	1.874	2.300	0.346	2.020	2.366	0.736	4.134	3.213	3.614	0.520
1.375	2.000	2.439	0.366	2.000	2.366	0.736	4.724	3.228	4.173	0.551
1.500	2.250	2.675	0.417	2.044	2.461	0.736	4.756	3.598	4.205	0.551
1.625	2.374	2.789	0.346	2.114	2.461	0.736	4.882	3.768	4.319	0.563
1.750	2.480	2.876	0.386	2.075	2.461	0.736	5.000	3.874	4.437	0.563
1.875	2.625	2.931	0.417	2.043	2.461	0.736	5.000	3.874	4.437	0.563
2.000	2.750	3.100	0.311	2.287	2.598	0.736	5.382	4.000	4.819	0.563
2.125	2.874	3.300	0.378	2.220	2.598	0.736	5.740	4.469	5.055	0.685
2.250	3.000	3.500	0.366	2.232	2.598	0.740	6.382	4.567	5.697	0.685
2.375	3.125	3.659	0.366	2.232	2.598	0.740	6.382	4.720	5.697	0.685
2.500	3.374	3.856	0.138	2.461	2.598	0.756	6.634	5.000	5.949	0.685
2.625	3.626	4.053	0.429	2.287	2.717	0.756	6.634	5.169	5.949	0.685
2.750	3.626	4.053	0.429	2.287	2.717	0.756	6.634	5.169	5.949	0.685
2.875	3.752	4.230	0.429	2.287	2.717	0.756	6.882	5.311	6.197	0.685
3.000	4.000	4.431	0.394	2.323	2.717	0.756	7.634	5.720	6.823	0.811
3.125	4.126	4.785	0.413	2.390	2.803	1.524	7.756	5.846	6.945	0.811
3.250	4.134	4.679	0.425	2.378	2.803	0.630	7.319	5.846	6.508	0.811
3.375	4.374	5.033	0.413	2.390	2.803	1.524	8.008	6.094	7.197	0.811
3.500	4.500	5.041	0.413	2.390	2.803	1.524	8.134	6.220	7.323	0.811
3.625	4.626	5.098	0.413	2.390	2.803	1.524	8.256	6.252	7.445	0.811
3.750	4.724	5.201	0.413	2.390	2.803	1.525	8.634	6.654	7.823	0.811
4.000	5.000	5.625	0.413	2.390	2.803	1.524	8.882	6.760	8.071	0.811
4.500	5.500	6.183	0.413	2.390	2.803	1.524	9.382	7.260	8.571	0.811
4.750	5.752	6.315	0.413	2.390	2.803	1.524	10.256	7.457	9.445	0.811
5.000	6.760	7.260	0.425	2.831	3.256	2.110	11.882	9.882	11.071	0.811
5.250	7.012	7.512	0.425	2.831	3.256	2.110	12.134	10.134	11.323	0.811
5.500	7.500	8.000	0.425	2.831	3.256	2.110	12.567	10.382	11.630	0.937

BIG BORE DIMENSIONS

Shaft Diameter	Box Bore		IB	OB	OAL	L	Gland Diameter	BCD		Bolt Slot
	Min	Max						Min	Max	
A	B	B	I	J	K	L	Gland OD			U
1.000	2.457	2.856	0.346	1.953	2.299	0.539	4.976	3.654	4.413	0.563
1.125	2.516	2.911	0.390	1.976	2.366	0.575	5.000	3.689	4.449	0.501
1.375	2.626	3.175	0.366	2.000	2.366	1.520	5.374	3.937	4.823	0.501
1.625	3.362	4.033	0.346	2.114	2.461	0.669	6.500	5.000	5.811	0.689
1.750	3.252	4.110	0.386	2.075	2.461	1.520	6.752	4.937	6.201	0.501
1.875	3.626	3.970	0.417	2.043	2.461	1.520	6.752	4.937	6.201	0.551
2.000	3.823	4.348	0.311	2.287	2.598	0.697	7.083	5.283	6.394	0.689
2.125	3.543	4.175	0.378	2.220	2.598	1.539	7.646	5.315	6.957	0.689
2.500	4.724	5.124	0.138	2.461	2.598	0.654	8.000	5.370	7.311	0.689
2.750	4.744	5.108	0.429	2.287	2.717	0.654	8.346	6.063	7.657	0.689
3.000	5.047	5.494	0.394	2.323	2.717	0.654	8.598	5.823	7.787	0.811
4.000	6.189	6.832	0.413	2.390	2.803	1.524	10.181	8.138	9.354	0.827

T.A.C. SERIES

TAC 44

TAC 44 - Standard Dimensions

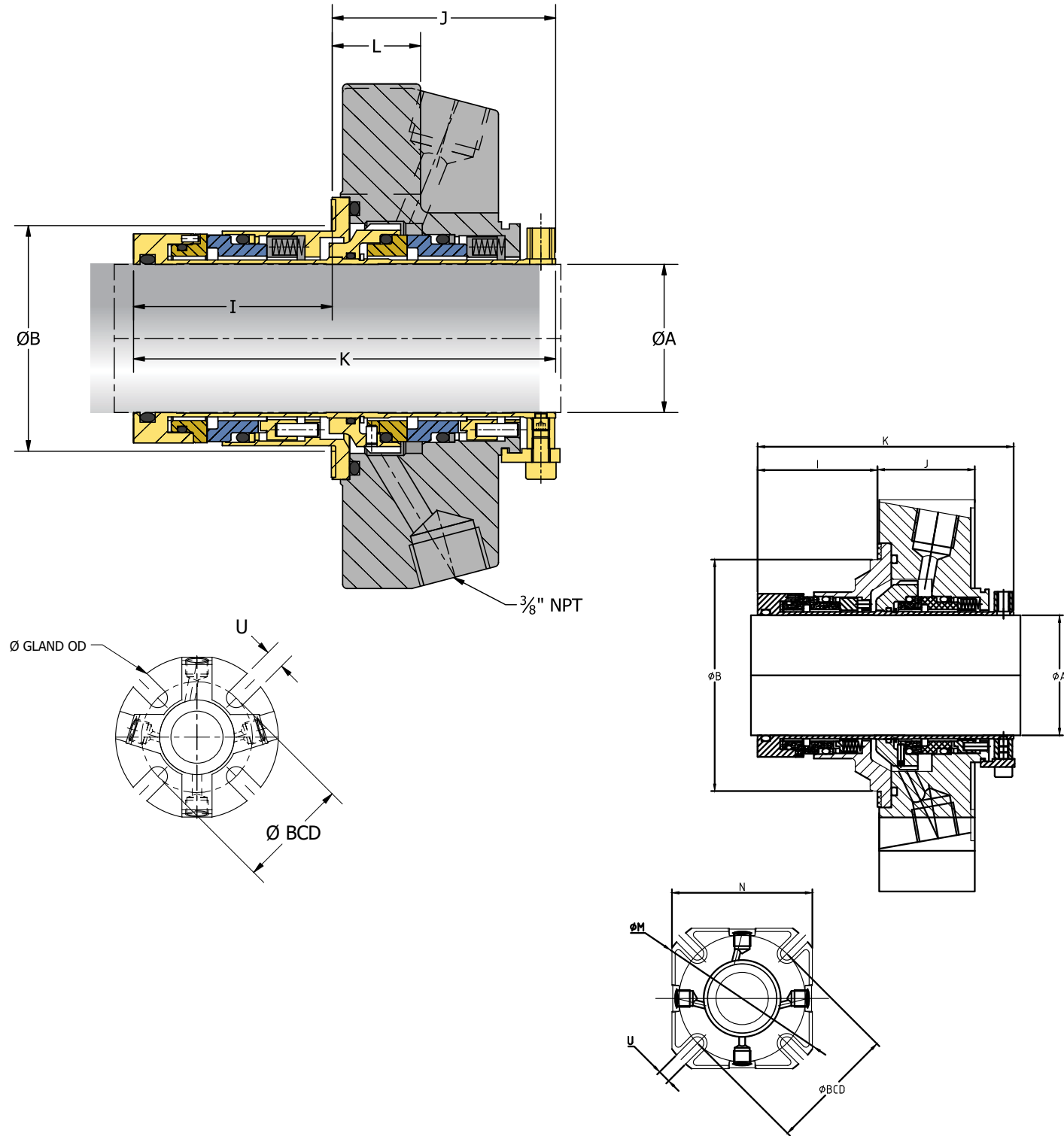

Shaft Diameter	Box Bore		IB	OB	OAL	L	Gland Diameter	BCD		Bolt Slot
	Min	Max						Min	Max	
A	B	B	I	J	K	L	Gland OD			U
1.000	1.626	1.970	1.776	1.929	3.705	0.630	3.882	2.803	3.362	0.520
1.125	1.752	2.057	1.799	2.039	3.839	0.831	4.008	2.929	3.488	0.520
1.250	1.874	2.309	1.799	2.039	3.839	0.811	4.134	3.213	3.614	0.520
1.375	2.000	2.439	1.799	2.039	3.839	0.811	4.724	3.228	4.173	0.551
1.500	2.252	2.675	1.870	2.126	3.996	0.811	4.756	3.598	4.205	0.551
1.625	2.374	2.789	1.870	2.130	4.000	0.811	4.882	3.778	4.319	0.563
1.750	2.480	2.876	1.870	2.130	4.000	0.811	5.000	3.875	4.437	0.563
1.875	2.625	2.931	1.870	2.130	4.000	0.811	5.000	3.875	4.437	0.563
2.000	2.756	3.108	2.067	2.287	4.354	0.811	5.382	4.000	4.819	0.563
2.125	2.874	3.321	2.067	2.287	4.354	0.807	5.740	4.469	5.055	0.685
2.250	3.000	3.525	2.067	2.287	4.354	0.811	6.382	4.567	5.697	0.685
2.375	3.126	3.659	2.102	2.441	4.543	0.811	6.382	4.720	5.697	0.685
2.500	3.375	3.856	2.004	2.539	4.543	0.799	6.634	5.000	5.949	0.685
2.625	3.626	4.053	2.118	2.476	4.594	0.811	6.634	5.169	5.949	0.685
2.750	3.626	4.125	2.118	2.476	4.594	0.811	6.634	5.169	5.949	0.685
2.875	3.752	4.230	2.118	2.476	4.594	0.811	6.882	5.311	6.197	0.685
3.000	4.000	4.431	2.055	2.539	4.594	0.811	7.634	5.720	6.823	0.811
3.125	4.126	4.785	2.150	2.539	4.689	1.594	7.756	5.846	6.945	0.811
3.250	4.134	4.679	2.201	2.488	4.689	0.728	7.319	5.846	6.508	0.811
3.375	4.374	5.033	2.150	2.539	4.689	1.602	8.008	6.094	7.197	0.811
3.500	4.500	5.041	2.150	2.539	4.689	1.602	8.134	6.220	7.323	0.811
3.625	4.625	5.098	2.150	2.539	4.689	1.602	8.256	6.252	7.445	0.811
3.750	4.724	5.201	2.150	2.539	4.689	1.602	8.634	6.654	7.823	0.811
4.000	5.000	5.565	2.150	2.539	4.689	1.638	8.882	6.760	8.071	0.811
4.500	5.500	6.183	2.150	2.539	4.689	1.638	9.382	7.260	8.571	0.811
4.750	5.751	6.315	2.150	2.539	4.689	1.594	10.256	7.456	9.444	0.811
5.000	6.760	7.260	2.496	3.020	5.516	1.748	11.882	9.882	11.071	0.811
5.250	7.012	7.512	2.496	3.020	5.516	1.748	12.134	10.134	11.323	0.811
5.500	7.500	8.000	2.496	3.020	5.516	1.748	12.567	10.382	11.630	0.937

BIG BORE DIMENSIONS

Shaft Diameter	Box Bore		IB	OB	OAL	L	Gland Diameter	BCD		Bolt Slot
	Min	Max						Min	Max	
A	B	B	I	J	K	L	Gland OD			U
1.125	2.516	2.911	1.799	2.039	3.839	0.618	5.000	3.689	4.480	0.520
1.375	2.787	3.175	1.799	2.039	3.839	1.520	5.374	3.937	4.823	0.551
1.625	3.362	4.033	1.870	2.126	3.996	0.669	6.500	5.000	5.937	0.563
1.750	3.252	4.110	1.870	2.126	3.996	1.520	6.752	4.937	6.189	0.563
1.875	3.614	3.970	1.870	2.126	3.996	1.520	6.752	4.937	6.189	0.563
2.000	3.823	4.348	2.067	2.287	4.354	0.697	7.083	5.287	6.394	0.689
2.500	4.752	5.123	2.004	2.539	4.543	0.654	8.000	5.370	7.311	0.689
2.750	4.740	5.108	2.118	2.476	4.594	0.654	8.346	6.063	7.657	0.689
3.000	5.047	5.494	2.055	2.539	4.594	0.654	8.598	6.634	7.787	0.811
3.500	5.571	6.175	2.150	2.539	4.689	1.602	9.433	7.402	8.622	0.811
4.000	6.189	6.832	2.150	2.539	4.689	1.638	10.181	8.138	9.370	0.811

Other Products

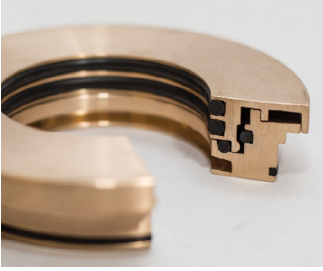

BEARING ISOLATORS

The Thomson QXE bearing isolator combines proven labyrinth technology with an innovative expeller design. It provides reliable bearing protection that minimizes shaft wear by eliminating oil leaks, preventing contamination and improving lubrication.



SUPPLY TANKS

In addition to A.R. Thomson's wide range of mechanical seals, we also offer supply tanks manufactured to ASME standard pressure vessel codes for safe, efficient and reliable seal operation.

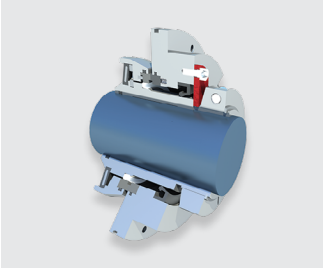

SLURRY SEALS

The Thomson Slurry Ace and Slurry Pro are designed to withstand the toughest industrial slurry pump services. The Slurry Ace is a medium duty seal designed to handle slurry with 40% solids while The Slurry Pro is a heavy duty seal for slurry with 60% solids. Both feature flushless operation which reduces operating costs.

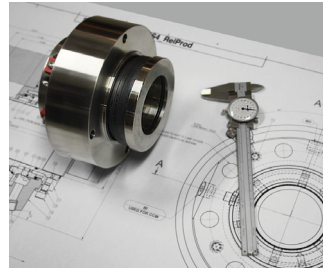

MECHANICAL SEAL REPAIR

A.R. Thomson Group's mechanical seal service facilities can repair any seal brand in the market. We also provide seal failure analysis, design upgrades and other custom engineered solutions tailored to your requirements. Contact us today for more information.

The A.R. Thomson Group was established in 1967 as a regional manufacturer & distributor of gaskets and other fluid containment products. With the rapid growth of oil and gas production, petrochemical, oil refining and pulp and paper industries, our manufacturing facilities expanded to meet increased demand for these products. Since 1967, we have developed our expertise and know-how to become the leader in solving fluid containment and control problems. No matter what your control or containment needs, we can help.



Fluid Containment And Control Specialists Since 1967

