

Forged Fittings



Forged Steel Socket-Weld & Threaded Fittings

1. PRESSURE RATINGS

These fittings shall be designated as pressure class 2000, 3000, and 6000 fittings for threading and pressure class 3000, 6000, and 9000 for socket-welding as shown on Table 1.

Table 1 : Correlation of Fittings Class with Schedule Number of Wall Designation of Pipe for Calculation of Ratings

Pressure Class Designation of Fitting	Type of Fitting	Pipe Used for Rating Basic	
		Schedule NO.	Wall Designation
2000 lb	Threaded	80	X-S
3000 lb	Threaded	160	-
6000 lb	Threaded	-	XX-S
3000 lb	Socket-Welding	80	X-S
6000 lb	Socket-Welding	160	-
9000 lb	Socket-Welding	-	XX-S

• Pipe actually used may be thinner or thicker in nominal wall than that shown in Table 1. When thinner is used its strength may govern the rating. When thicker pipe is used (e.g., for mechanical strength) the strength of the fitting governs the rating.

Table 2 : Nominal Wall Thickness of Schedule 160 and Double Extra Strong Pipe

NPS.	Schedule 160		XX - S	
	in	mm	in	mm
1/8	0.124	3.15	0.190	4.83
1/4	0.145	3.68	0.230	6.05
3/8	0.158	4.01	0.252	6.40

Table 3 : Pressure/Temperature Ratings

Non-shock working pressure in pounds per square inch.

Service Temperature Degree °F	2000lb Threaded Fittings					3000lb Socket Welding and Threaded Fittings					6000lb Socket Welding and Threaded Fittings				
	Carbon Steel	F304	F316	F22	F5	Carbon Steel	F304	F316	F22	F5	Carbon Steel	F304	F316	F22	F5
100	2000	1715	2000	2000	2000	3000	2570	3000	3000	3000	6000	5145	6000	6000	6000
150	1970	1615	1970	1970	1970	2950	2425	2950	2950	2950	5915	4855	5915	5915	5915
200	1940	1520	1940	1940	1940	2915	2280	2915	2915	2915	5830	4565	5830	5830	5830
250	1915	1445	1915	1915	1915	2875	2170	2975	2975	2975	5750	4340	5750	5750	5750
300	1975	1370	1896	1895	1896	2845	2055	2845	2845	2845	5690	4115	5690	5690	5690
350	1875	1310	1875	1875	1875	2810	1965	2810	2810	2810	5625	3930	5625	5625	5625
400	1850	1245	1850	1850	1850	2775	1870	2775	2775	2775	5550	3745	5550	5550	5550
450	1810	1195	1810	1710	1810	2715	1790	2715	2715	2715	5430	3585	5430	5430	5430
500	1735	1140	1735	1635	1735	2605	1715	2605	2605	2605	5210	3430	5210	5210	5210
550	1640	1100	1640	1540	1640	2460	1650	2460	2460	2460	4925	3305	4925	4925	4925
600	1540	1060	1540	1440	1540	2310	1590	2310	2310	2310	4620	3180	4620	4620	4620
650	1430	1020	1430	1330	1430	2150	1535	2150	2150	2150	4300	3070	4300	4300	4300
700	1305	985	1370	1240	1340	1960	1480	2055	2010	2010	3920	2960	4110	4025	4025
750	1180	950	1305	1145	1245	1775	1425	1960	1870	1870	3550	2850	3920	3745	3745
800	1015	915	1240	1055	1155	1525	1370	1865	1735	1735	3050	2745	3730	3470	3470
850	830	880	1180	1060	1060	1250	1330	1770	1595	1595	2500	2660	3540	3190	3190
900	615	860	1115	970	970	925	1290	1675	1455	1455	1885	2580	3350	2915	2915
950	425	845	1055	880	880	640	1270	1580	1320	1320	1295	2540	3165	2640	2640
1000	235	830	990	740	695	350	1250	1485	1115	1240	715	2500	2975	2230	2085

Forged Steel Socket-Weld & Threaded Fittings

2. SIZE IDENTIFICATION

The size of a fitting is identified by the nominal pipe size. For reducing fittings, the size of the largest run opening is to be given first, followed by the size of the opening opposite of the same run. The branch size of a Tee is given last. Where the case is a Cross, the largest side-outlet is given third, then the opening opposite.

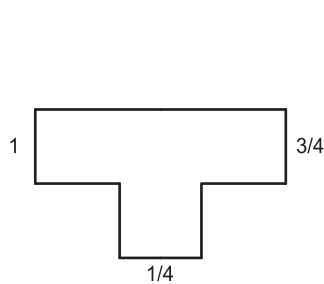

Tee
1 x 3/4 x 1/4

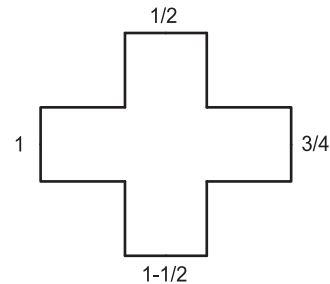

Cross
1-1/2 x 1/2 x 1 x 3/4

3. THREADS

Unless otherwise specified in inquiry, all threaded fittings are supplied with NPT threads (ANSI B2.1 American Standard. Taper Pipe Thread) for reference, other available threads are :

- ISO / R7, Pipe Threads for Gas List Tubes and Screwed Fittings where Pressure-tight Joints are made on the threads. (BS 2.1 & JIS B0203 PT Thread).
- API 5B, Line Pipe Threads.
- KS B0222 Taper Pipe Threads.

4. BORE DIAMETER OF FITTINGS

Bore Diameter of fittings conform to ANSI, MSS, JIS or KS dimensions.

Forged Steel Socket-Weld Fittings

90° ELBOW

3000# 6000# 9000#

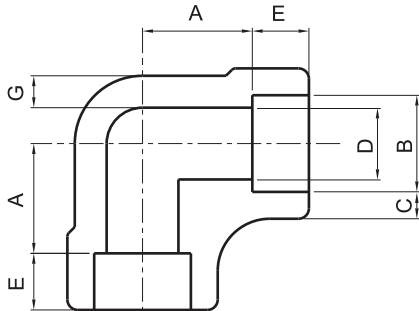

3000# (mm) ANSI B16.11

Pipe Size	A	B	C	D	E	G
1/8	12.0 10.0	10.90 10.65	3.20	7.6 6.1	10.0	2.40
1/4	12.0 10.0	14.35 14.10	3.80	10.0 8.5	10.0	3.00
3/8	15.0 12.0	17.80 17.55	4.00	13.3 11.8	10.0	3.20
1/2	17.0 14.0	21.95 21.70	4.65	16.6 15.0	10.0	3.75
3/4	21.0 18.0	27.30 27.05	4.90	21.7 20.2	13.0	3.90
1	24.0 20.0	34.05 33.80	5.70	27.4 25.9	13.0	4.55
1-1/4	29.0 25.0	42.80 42.55	6.05	35.8 34.3	13.0	4.85
1-1/2	34.0 30.0	48.90 48.65	6.35	41.7 40.1	13.0	5.10
2	40.0 36.0	61.35 61.10	6.95	53.5 51.7	16.0	5.55
2-1/2	44.0 39.0	74.20 73.80	8.75	64.2 61.2	16.0	7.00
3	60.0 55.0	90.15 89.80	9.50	79.5 76.4	16.0	7.60
4	69.0 64.0	115.80 115.45	10.70	103.8 100.7	19.0	8.55

6000# (mm) ANSI B16.11

Pipe Size	A	B	C	D	E	G
1/8	12.0 10.0	10.90 10.65	3.95	4.8 3.2	10.0	3.15
1/4	17.0 13.0	14.35 14.10	4.60	7.1 5.6	10.0	3.70
3/8	17.0 14.0	17.80 17.55	5.05	9.9 8.4	10.0	4.00
1/2	21.0 18.0	21.95 21.70	5.95	12.5 11.0	10.0	4.80
3/4	24.0 21.0	27.30 27.05	6.95	16.3 14.8	13.0	5.55
1	29.0 25.0	34.05 33.80	7.90	21.5 19.9	13.0	6.35
1-1/4	34.0 30.0	42.80 42.55	7.90	30.2 28.7	13.0	6.35
1-1/2	40.0 36.0	48.90 48.65	8.90	34.7 33.2	13.0	7.15
2	43.0 39.0	61.35 61.10	10.90	43.6 42.1	16.0	8.75

9000# (mm) ANSI B16.11

Pipe Size	A	B	C	D	E	G
1/2	27.0 24.0	21.95 21.70	9.35	7.2 5.6	10.0	7.45
3/4	30.0 27.0	27.30 27.05	9.80	11.8 10.3	13.0	7.80
1	34.0 30.0	34.05 33.80	11.40	16.0 14.5	13.0	9.10
1-1/4	37.0 33.0	42.80 42.55	12.15	23.5 22.0	13.0	9.70
1-1/2	40.0 36.0	48.90 48.65	12.70	28.7 27.2	13.0	10.15
2	56.0 52.0	61.35 61.10	13.85	38.9 37.4	16.0	11.05

45° ELBOW

3000# 6000# 9000#

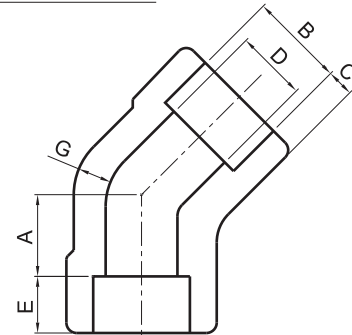

3000# (mm) ANSI B16.11

Pipe Size	A	B	C	D	E	G
1/8	9.0 7.0	10.90 10.65	3.20	7.6 6.1	10.0	2.40
1/4	9.0 7.0	14.35 14.10	3.80	10.0 8.5	10.0	3.00
3/8	9.0 6.0	17.80 17.55	4.00	13.3 11.8	10.0	3.20
1/2	13.0 10.0	21.95 21.70	4.65	16.6 15.0	10.0	3.75
3/4	14.0 11.0	27.30 27.05	4.90	21.7 20.2	13.0	3.90
1	16.0 12.0	34.05 33.80	5.70	27.4 25.9	13.0	4.55
1-1/4	19.0 15.0	42.80 42.55	6.05	35.8 34.3	13.0	4.85
1-1/2	23.0 19.0	48.90 48.65	6.35	41.7 40.1	13.0	5.10
2	27.0 23.0	61.35 61.10	6.95	53.5 51.7	16.0	5.55
2-1/2	31.0 27.0	74.20 73.80	8.75	64.2 61.2	16.0	7.00
3	34.0 29.0	90.15 89.80	9.50	79.5 76.4	16.0	7.60
4	44.0 39.0	115.80 115.45	10.70	103.8 100.7	19.0	8.55

6000# (mm) ANSI B16.11

Pipe Size	A	B	C	D	E	G
1/8	9.0 7.0	10.90 10.65	3.95	4.8 3.2	10.0	3.15
1/4	9.0 7.0	14.35 14.10	4.60	7.1 5.6	10.0	3.70
3/8	13.0 10.0	17.80 17.55	5.05	9.9 8.4	10.0	4.00
1/2	14.0 11.0	21.95 21.70	5.95	12.5 11.0	10.0	4.80
3/4	16.0 13.0	27.30 27.05	6.95	16.3 14.8	13.0	5.55
1	19.0 15.0	34.05 33.80	7.90	21.5 19.9	13.0	6.35
1-1/4	23.0 19.0	42.80 42.55	7.90	30.2 28.7	13.0	6.35
1-1/2	27.0 23.0	48.90 48.65	8.90	34.7 33.2	13.0	7.15
2	31.0 27.0	61.35 61.10	10.90	43.6 42.1	16.0	8.75

9000# (mm) ANSI B16.11

Pipe Size	A	B	C	D	E	G
1/2	17.0 14.0	21.95 21.70	9.35	7.2 5.6	10.0	7.45
3/4	21.0 17.0	27.30 27.05	9.80	11.8 10.3	13.0	7.80
1	23.0 19.0	34.05 33.80	11.40	16.0 14.5	13.0	9.10
1-1/4	24.0 20.0	42.80 42.55	12.15	23.5 22.0	13.0	9.70
1-1/2	28.0 23.0	48.90 48.65	12.70	28.7 27.2	13.0	10.15
2	31.0 26.0	61.35 61.10	13.85	38.9 37.4	16.0	11.05

Forged Steel Socket-Weld Fittings

TEE

3000# 6000# 9000#

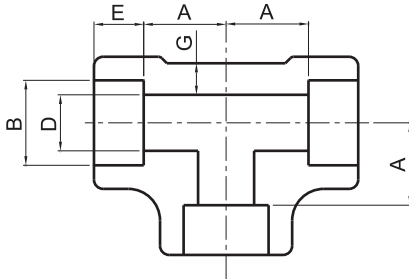

3000# (mm) ANSI B16.11

Pipe Size	A	B	C	D	E	G
1/8	12.0 10.0	10.90 10.65	3.20	7.6 6.1	10.0	2.40
1/4	12.0 10.0	14.35 14.10	3.80	10.0 8.5	10.0	3.00
3/8	15.0 12.0	17.80 17.55	4.00	13.3 11.8	10.0	3.20
1/2	17.0 14.0	21.95 21.70	4.65	16.6 15.0	10.0	3.75
3/4	21.0 18.0	27.30 27.05	4.90	21.7 20.2	13.0	3.90
1	24.0 20.0	34.05 33.80	5.70	27.4 25.9	13.0	4.55
1-1/4	29.0 25.0	42.80 42.55	6.05	35.8 34.3	13.0	4.85
1-1/2	34.0 30.0	48.90 48.65	6.35	41.7 40.1	13.0	5.10
2	40.0 36.0	61.35 61.10	6.95	53.5 51.7	16.0	5.55
2-1/2	44.0 39.0	74.20 73.80	8.75	64.2 61.2	16.0	7.00
3	60.0 55.0	90.15 89.80	9.50	79.5 76.4	16.0	7.60
4	69.0 64.0	115.80 115.45	10.70	103.8 100.7	19.0	8.55

6000# (mm) ANSI B16.11

Pipe Size	A	B	C	D	E	G
1/8	12.0 10.0	10.90 10.65	3.95	4.8 3.2	10.0	3.15
1/4	17.0 13.0	14.35 14.10	4.60	7.1 5.6	10.0	3.70
3/8	17.0 14.0	17.80 17.55	5.05	9.9 8.4	10.0	4.00
1/2	21.0 18.0	21.95 21.70	5.95	12.5 11.0	10.0	4.80
3/4	24.0 21.0	27.30 27.05	6.95	16.3 14.8	13.0	5.55
1	29.0 25.0	34.05 33.80	7.90	21.5 19.9	13.0	6.35
1-1/4	34.0 30.0	42.80 42.55	7.90	30.2 28.7	13.0	6.35
1-1/2	40.0 36.0	48.90 48.65	8.90	34.7 33.2	13.0	7.15
2	43.0 39.0	61.35 61.10	10.90	43.6 42.1	16.0	8.75

9000# (mm) ANSI B16.11

Pipe Size	A	B	C	D	E	G
1/2	27.0 24.0	21.95 21.70	9.35	7.2 5.6	10.0	7.45
3/4	30.0 27.0	27.30 27.05	9.80	11.8 10.3	13.0	7.80
1	34.0 30.0	34.05 33.80	11.40	16.0 14.5	13.0	9.10
1-1/4	37.0 33.0	42.80 42.55	12.15	23.5 22.0	13.0	9.70
1-1/2	40.0 36.0	48.90 48.65	12.70	28.7 27.2	13.0	10.15
2	56.0 52.0	61.35 61.10	13.85	38.9 37.4	16.0	11.05

CROSS

3000# 6000# 9000#

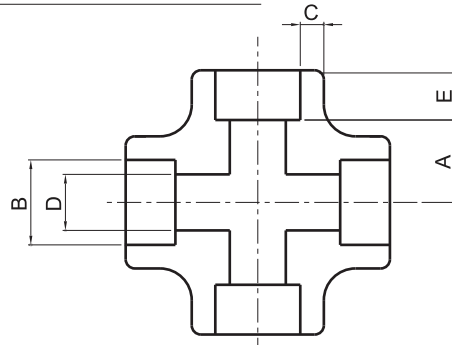

3000# (mm) ANSI B16.11

Pipe Size	A	B	C	D	E
1/8	12.0 10.0	10.90 10.65	3.20	7.6 6.1	10.0
1/4	12.0 10.0	14.35 14.10	3.80	10.0 8.5	10.0
3/8	15.0 12.0	17.80 17.55	4.00	13.3 11.8	10.0
1/2	17.0 14.0	21.95 21.70	4.65	16.6 15.0	10.0
3/4	21.0 18.0	27.30 27.05	4.90	21.7 20.2	13.0
1	24.0 20.0	34.05 33.80	5.70	27.4 25.9	13.0
1-1/4	29.0 25.0	42.80 42.55	6.05	35.8 34.3	13.0
1-1/2	34.0 30.0	48.90 48.65	6.35	41.7 40.1	13.0
2	40.0 36.0	61.35 61.10	6.95	53.5 51.7	16.0
2-1/2	44.0 39.0	74.20 73.80	8.75	64.2 61.2	16.0
3	60.0 55.0	90.15 89.80	9.50	79.5 76.4	16.0
4	69.0 64.0	115.80 115.45	10.70	103.8 100.7	19.0

6000# (mm) ANSI B16.11

Pipe Size	A	B	C	D	E
1/8	12.0 10.0	10.90 10.65	3.95	4.8 3.2	10.0
1/4	17.0 13.0	14.35 14.10	4.60	7.1 5.6	10.0
3/8	17.0 14.0	17.80 17.55	5.05	9.9 8.4	10.0
1/2	21.0 18.0	21.95 21.70	5.95	12.5 11.0	10.0
3/4	24.0 21.0	27.30 27.05	6.95	16.3 14.8	13.0
1	29.0 25.0	34.05 33.80	7.90	21.5 19.9	13.0
1-1/4	34.0 30.0	42.80 42.55	7.90	30.2 28.7	13.0
1-1/2	40.0 36.0	48.90 48.65	8.90	34.7 33.2	13.0
2	43.0 39.0	61.35 61.10	10.90	43.6 42.1	16.0

9000# (mm) ANSI B16.11

Pipe Size	A	B	C	D	E
1/2	27.0 24.0	21.95 21.70	9.35	7.2 5.6	10.0
3/4	30.0 27.0	27.30 27.05	9.80	11.8 10.3	13.0
1	34.0 30.0	34.05 33.80	11.40	16.0 14.5	13.0
1-1/4	37.0 33.0	42.80 42.55	12.15	23.5 22.0	13.0
1-1/2	40.0 36.0	48.90 48.65	12.70	28.7 27.2	13.0
2	56.0 52.0	61.35 61.10	13.85	38.9 37.4	16.0

Forged Steel Socket-Weld Fittings

FULL COUPLING

3000# 6000# 9000#

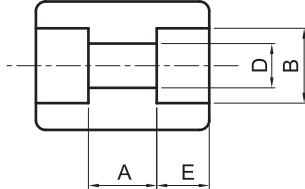

3000# (mm) ANSI B16.11

Pipe Size	A	B	D	E
1/8	8.0 5.0	10.90 10.65	7.6 6.1	10.0
1/4	8.0 5.0	14.35 14.10	10.0 8.5	10.0
3/8	9.0 3.0	17.80 17.55	13.3 11.8	10.0
1/2	13.0 6.0	21.95 21.70	16.6 15.0	10.0
3/4	13.0 6.0	27.30 27.05	21.7 20.2	13.0
1	17.0 9.0	34.05 33.80	27.4 25.9	13.0
1-1/4	17.0 9.0	42.80 42.55	35.8 34.3	13.0
1-1/2	17.0 9.0	48.90 48.65	41.7 40.1	13.0
2	23.0 15.0	61.35 61.10	53.5 51.7	16.0
2-1/2	24.0 14.0	74.20 73.80	64.2 61.2	16.0
3	24.0 14.0	90.15 89.80	79.5 76.4	16.0
4	24.0 14.0	115.80 115.45	103.8 100.7	19.0

6000# (mm) ANSI B16.11

Pipe Size	A	B	D	E
1/2	13.0 6.0	21.95 21.70	12.5 11.0	10.0
3/4	13.0 6.0	27.30 27.05	16.3 14.8	13.0
1	17.0 9.0	34.05 33.80	21.5 19.9	13.0
1-1/4	17.0 9.0	42.80 42.55	30.2 28.7	13.0
1-1/2	17.0 9.0	48.90 48.65	34.7 33.2	13.0
2	23.0 15.0	61.35 61.10	43.6 42.1	16.0
2-1/2	24.0 14.0	74.20 73.80	64.2 61.2	16.0
3	24.0 14.0	90.15 89.80	79.5 76.4	16.0
4	24.0 14.0	115.80 115.45	103.8 100.7	19.0

9000# (mm) ANSI B16.11

Pipe Size	A	B	D	E
1/2	13.0 6.0	21.95 21.70	7.2 5.6	10.0
3/4	13.0 6.0	27.30 27.05	11.8 10.3	13.0
1	17.0 9.0	34.05 33.80	16.0 14.5	13.0
1-1/4	17.0 9.0	42.80 42.55	23.5 22.0	13.0
1-1/2	17.0 9.0	48.90 48.65	28.7 27.2	13.0
2	23.0 15.0	61.35 61.10	38.9 37.4	16.0
2-1/2	24.0 14.0	74.20 73.80	64.2 61.2	16.0
3	24.0 14.0	90.15 89.80	79.5 76.4	16.0
4	24.0 14.0	115.80 115.45	103.8 100.7	19.0

HALF COUPLING

3000# 6000# 9000#

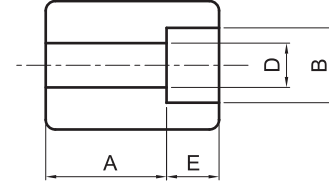

3000# (mm) ANSI B16.11

Pipe Size	A	B	D	E
1/8	17.0 15.0	10.90 10.65	7.6 6.1	10.0
1/4	17.0 15.0	14.35 14.10	10.0 8.5	10.0
3/8	19.0 16.0	17.80 17.55	13.3 11.8	10.0
1/2	24.0 21.0	21.95 21.70	16.6 15.0	10.0
3/4	25.0 22.0	27.30 27.05	21.7 20.2	13.0
1	31.0 27.0	34.05 33.80	27.4 25.9	13.0
1-1/4	32.0 28.0	42.80 42.55	35.8 34.3	13.0
1-1/2	34.0 30.0	48.90 48.65	41.7 40.1	13.0
2	43.0 39.0	61.35 61.10	53.5 51.7	16.0
2-1/2	45.0 40.0	74.20 73.80	64.2 61.2	16.0
3	47.0 42.0	90.15 89.80	79.5 76.4	16.0
4	50.0 45.0	115.80 115.45	103.8 100.7	19.0

6000# (mm) ANSI B16.11

Pipe Size	A	B	D	E
1/2	24.0 21.0	21.95 21.70	12.5 11.0	10.0
3/4	25.0 22.0	27.30 27.05	16.3 14.8	13.0
1	31.0 27.0	34.05 33.80	21.5 19.9	13.0
1-1/4	32.0 28.0	42.80 42.55	30.2 28.7	13.0
1-1/2	34.0 30.0	48.90 48.65	34.7 33.2	13.0
2	43.0 39.0	61.35 61.10	43.6 42.1	16.0
2-1/2	45.0 40.0	74.20 73.80	64.2 61.2	16.0
3	47.0 42.0	90.15 89.80	79.5 76.4	16.0
4	50.0 45.0	115.80 115.45	103.8 100.7	19.0

9000# (mm) ANSI B16.11

Pipe Size	A	B	D	E
1/2	24.0 21.0	21.95 21.70	7.2 5.6	10.0
3/4	25.0 22.0	27.30 27.05	11.8 10.3	13.0
1	31.0 27.0	34.05 33.80	16.0 14.5	13.0
1-1/4	32.0 28.0	42.80 42.55	23.5 22.0	13.0
1-1/2	34.0 30.0	48.90 48.65	28.7 27.2	13.0
2	43.0 39.0	61.35 61.10	38.9 37.4	16.0
2-1/2	45.0 40.0	74.20 73.80	64.2 61.2	16.0
3	47.0 42.0	90.15 89.80	79.5 76.4	16.0
4	50.0 45.0	115.80 115.45	103.8 100.7	19.0

Forged Steel Socket-Weld Fittings

CAP

3000# 6000#

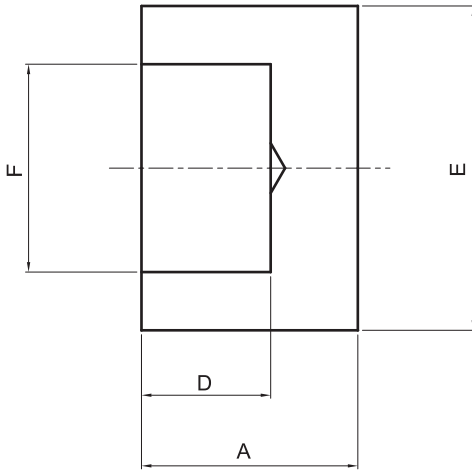

3000# (mm)

ANSI B16.11

Nom Size	A	E	F	D	Unit Weight(kg)
1/4	16	22	14.3	9.5	0.04
3/8	16	25.5	17.8	9.5	0.05
1/2	17.5	31.5	22.2	9.5	0.07
3/4	22.5	37	27.7	13	0.13
1	29	45.5	34.5	13	0.21
1-1/4	29	55	43.2	13	0.37
1-1/2	32	61.5	49.1	13	0.60
2	42	75	61.1	16	0.99
2-1/2	42	91.5	77.1	16	1.50
3	42	109	90.1	16	2.30
4	50	138	115.3	20	4.00

6000# (mm)

ANSI B16.11

Nom Size	A	E	F	D	Unit Weight(kg)
1/4	18	23	14.3	9.5	0.04
3/8	18	26.5	17.8	9.5	0.06
1/2	25.5	34	22.2	9.5	0.15
3/4	32	41	27.7	13	0.27
1	35.5	50	34.5	13	0.45
1-1/4	39	58.5	43.2	13	0.67
1-1/2	40	66.5	49.1	13	0.89
2	50	83	61.1	16	1.75
2-1/2	55	98	77.1	16	2.66
3	60	118	90.1	16	4.33
4	70	149	115.3	20	7.91

BOSS

3000# 6000#

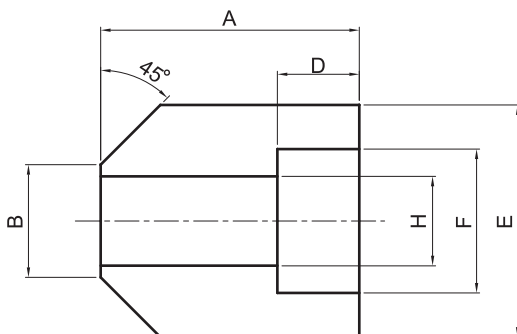

3000# / 6000# (mm)

ANSI B16.11

Nom Size	A	B	E	D	F	H	Unit Weight(kg)
1/4	30	18	32	10	14.3	8	0.09
3/8	30	21	35	10	17.8	11	0.11
1/2	33	24	38	10	22.2	15	0.14
3/4	35	27	45	13	27.7	19	0.20
1	43	34	57	13	34.5	25	0.43
1-1/4	46	42	67	13	43.2	33	0.72
1-1/2	50	49	76	13	49.1	39	0.85
2	57	61	89	16	61.1	50	1.36

Forged Steel Socket-Weld Fittings

UNION

3000#

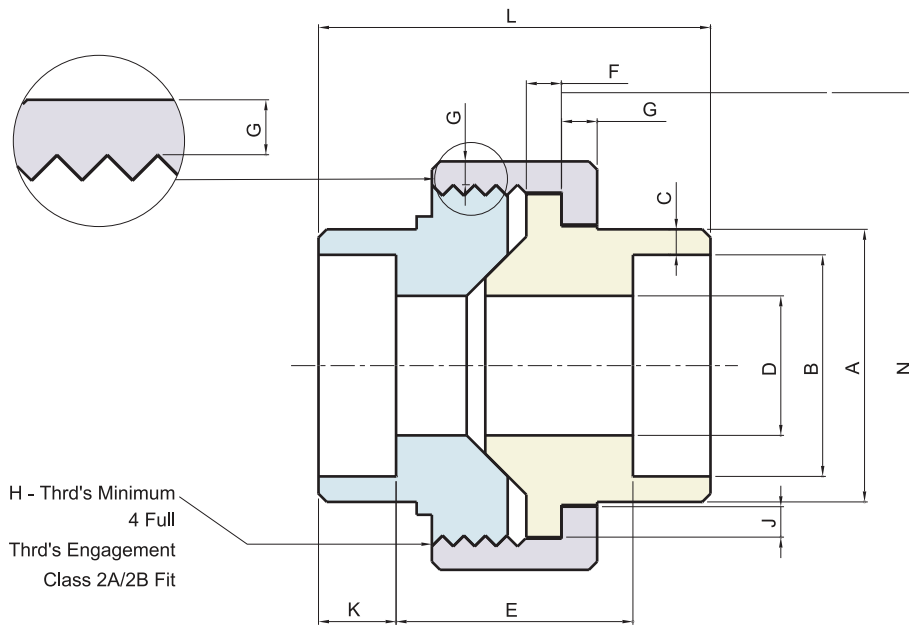

MSS SP-83

(mm)

Pipe Size	Pipe End Min. A	Socket Bore Dia. B	Socket Wall Min. C	Water Way Bore D	Laying Length E	Male Flange Min. F	Nut Min. G	Thrd's Per 25.4 Max. H	Bearing Min. J	Depth Of Socket Min. K	Length Assem. Nominal L	Clear Assem. Nut N
1/8	21.8	10.92 10.67	3.17	6.83 6.43	22.4 19.0	3.17	3.17	16	1.24	9.6	41.1	49.0
1/4	21.8	14.22 13.97	3.30	9.85 9.45	22.4 19.0	3.17	3.17	16	1.24	9.6	41.4	49.0
3/8	25.9	17.78 17.53	3.48	13.92 13.51	26.9 20.6	3.43	3.43	14	1.37	9.6	46.0	55.0
1/2	31.2	21.84 21.59	4.06	17.47 17.07	26.9 20.6	3.68	3.68	14	1.50	9.6	49.0	57.0
3/4	37.1	27.18 26.92	4.27	21.79 21.39	31.8 25.4	4.06	4.06	11	1.68	12.7	56.9	67.0
1	45.5	34.04 33.78	4.95	28.14 27.74	34.3 26.2	4.57	4.44	11	1.85	12.7	62.0	79.0
1-1/4	54.9	42.67 42.42	5.28	35.76 35.39	40.6 32.5	5.33	5.21	11	2.13	12.7	71.1	94.0
1-1/2	61.5	48.77 48.51	5.54	41.61 41.20	42.2 34.0	5.84	5.59	10	2.31	12.7	76.5	111.0
2	75.2	61.47 61.21	6.05	52.53 52.12	45.5 37.3	6.60	6.35	10	2.69	15.8	86.1	132.0
2-1/2	91.7	74.17 73.66	7.65	64.72 64.31	61.7 52.1	7.49	7.11	8	3.07	15.8	102.4	148.0
3	109.2	90.17 89.66	8.31	77.67 77.27	63.8 53.6	8.25	8.00	8	3.53	15.8	109.0	175.0

Forged Steel Socket-Weld Fittings

UNION

3000# 6000#

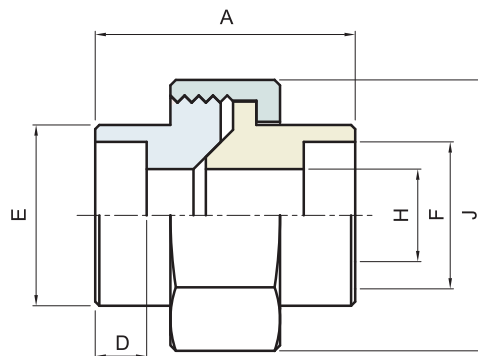

STANDARD

(mm)

Nom Size	A		D		E		F		H		J (Flat)		unit weight (kg)	
	3000	6000	3000	6000	3000	6000	3000	6000	3000	6000	3000	6000	3000	6000
1/4	45	51	9.5	9.5	21	24.5	14.3	14.3	7.8	6.5	32	38	0.23	0.25
3/8	51	54	9.5	9.5	24.5	31.5	17.8	17.8	10.9	9	38	46	0.35	0.42
1/2	54	57	9.5	9.5	31.5	41.5	22.2	22.2	14.3	12.3	46	51	0.40	0.85
3/4	57	64	13	13	37.5	41.5	27.7	27.7	19.4	16.2	51	60	0.50	1.00
1	64	72	13	13	44.5	48.8	34.5	34.5	25.0	21.2	60	72	0.70	1.30
1-1/4	72	80	13	13	54	56	43.2	43.2	32.9	29.9	72	77	1.20	2.00
1-1/2	80	89	13	13	61.5	69	49.1	49.1	38.4	34.4	80	94	1.50	3.80
2	89	110	16	16	74.5	90	61.1	61.1	49.5	43.1	94	120	2.58	6.40

UNION (O-RING TYPE)

3000#

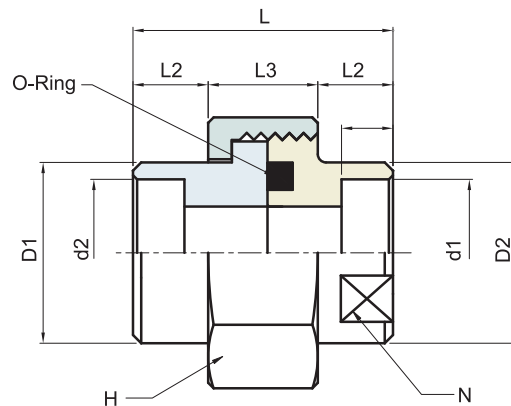

Rating Pressure : 210kg/cm²
Temperature : 120 °C MAX

(mm)

Nom Size	d1	d2	D1	D2	L1	L2	L3	L	N	H	O-RING
1/4	10	14.3	22	24	10	10	18	38	21	35HEX	P18
3/8	12	17.8	27	30	10	10	18	38	26	41HEX	P20
1/2	16	22.2	32	35	12	12	20	44	32	46HEX	G25
3/4	20	27.7	37	41	12	12	26	50	38	54HEX	G30
1	25	34.5	44	48	15	15	26	56	44	63HEX	G35
1-1/4	32	43.2	54	58	15	15	30	60	54	75HEX	G45
1-1/2	38	49.1	63	65	18	18	36	72	60	80OCT	G50
2	48	61.1	76	80	18	18	36	72	75	95OCT	G65

Forged Steel Socket-Weld Fittings

REDUCER INSERT

3000# 6000#

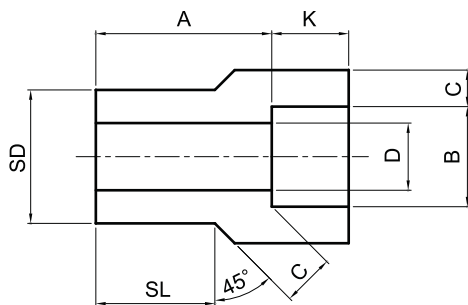

Type 1

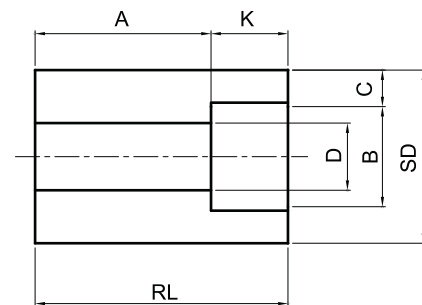

Type 2

MSS SP-79

(mm)

Pipe Size	Type		Socket		Shank Dia. SD	Laying Length A		Bore D		Wall Min. C		Length Min.			
			Dia. B	Depth Min. K		3000	6000	3000	6000	3000	6000	SL		RL	
	3000	6000										3000	6000	3000	6000
3/8 x 1/4	1	1	14.22	9.52	17.14	19.0	20.6	9.14	6.35	3.78	4.60	14.22	15.75		
1/2 x 3/8	1	1	17.65	9.52	21.34	20.6	22.2	12.45	9.14	4.01	5.03	15.75	17.27		
x 1/4	1	1	14.22	9.52	21.34	15.8	20.6	9.14	6.35	3.78	4.60	17.27	17.27		
3/4 x 1/2	1	1	21.84	9.52	26.67	22.2	25.4	15.75	11.68	4.67	5.97	17.53	19.05		
x 3/8	2	1	17.65	9.52	26.67	15.8	22.2	12.45	9.14	4.01	5.03		19.05	26.92	
x 1/4	2	2	14.22	9.52	26.67	17.5	22.2	9.14	6.35	3.78	4.60			26.92	29.97
1 x 3/4	1	1	27.18	12.70	33.35	23.8	28.5	20.83	15.49	4.90	6.96	19.05	20.57		
x 1/2	2	1	21.84	9.52	33.35	15.8	20.6	15.75	11.68	4.67	5.97		20.57	28.45	
x 3/8	2	2	17.65	9.52	33.35	17.5	22.2	12.45	9.14	4.01	5.03			28.45	33.27
x 1/4	2	2	14.22	9.52	33.35	19.0	23.8	9.14	6.35	3.78	4.60			28.45	33.27
1-1/4 x 1	1	1	33.86	12.70	42.16	25.4	30.2	26.67	20.57	5.69	7.92	20.57	22.35		
x 3/4	2	2	27.18	12.70	42.16	17.5	20.6	20.88	15.49	4.90	6.96			31.75	34.80
x 1/2	2	2	21.84	9.52	42.16	19.0	22.2	15.75	11.68	4.67	5.97			31.75	34.80
x 3/8	2	2	17.65	9.52	42.16	20.6	23.8	12.45	9.14	4.01	5.03			31.75	34.80
x 1/4	2	2	14.22	9.52	42.16	22.2	25.4	9.14	6.35	3.78	4.60			31.75	34.80
1-1/2 x 1-1/4	1	1	42.67	12.70	48.26	28.5	35.1	35.05	29.46	6.07	7.92	22.22	25.40		
x 1	2	1	33.86	12.70	48.26	17.5	28.5	26.67	20.57	5.69	7.92		25.40	33.27	
x 3/4	2	2	27.18	12.70	48.26	19.0	25.4	20.83	15.49	4.90	6.96			33.27	39.62
x 1/2	2	2	21.84	9.52	48.26	20.6	26.9	15.75	11.68	4.67	5.97			33.27	39.62
x 3/8	2	2	17.65	9.52	48.26	22.2	28.5	12.45	9.14	4.01	5.03			33.27	39.62
2 x 1-1/2	1	1	48.77	12.70	60.32	31.7	46.0	40.89	34.04	6.35	8.91	25.40	39.62		
x 1-1/4	2	2	42.67	12.70	60.32	20.6	23.8	34.92	29.46	6.07	7.92			38.10	45.97
x 1	2	2	33.91	12.70	60.32	22.2	25.4	26.67	20.83	5.69	7.92			38.10	45.97
x 3/4	2	2	27.18	12.70	60.32	23.8	26.9	20.83	15.49	4.90	6.96			38.10	45.97
x 1/2	2	2	21.84	9.52	60.32	25.4	28.5	15.87	11.68	4.67	5.97			38.10	45.97

Forged Steel Socket-Weld Fittings

REDUCER INSERT

3000# 6000#

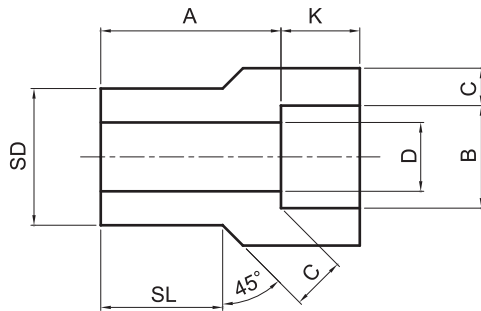

Type 1

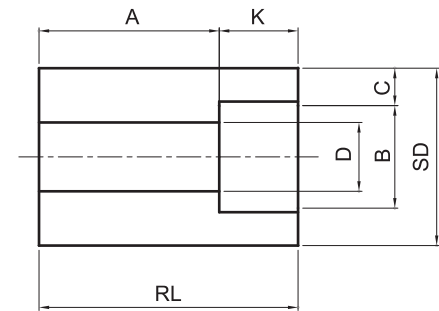

Type 2

MSS SP-79

(mm)

Pipe Size	Type		Socket		Shank Dia. SD	Laying Length A		Bore D		Wall Min. C		Length Min.			
			Dia. B	Depth Min. K		3000	6000	3000	6000	3000	6000	SL		RL	
	3000	6000										3000	6000	3000	6000
2-1/2 x 2 x 1-1/2 x 1-1/4 x 1 x 3/4	1	1	61.24	15.87	73.02	46.0	42.8	52.58	20.57	6.93	10.92	38.10	31.75		
	2	2	48.77	12.70	73.02	34.9		40.89		6.35				53.85	
	2	2	42.67	12.70	73.02	36.5		34.92		6.07				53.85	
	2	2	33.91	12.70	73.02	38.1		26.67		5.69				53.85	
	2	2	27.18	12.70	73.02	39.6		20.83		4.90				53.85	
3 x 2-1/2 x 2 x 1-1/2 x 1-1/4 x 1	1		74.01	15.87	88.90	38.1		62.74		8.76		31.75			
	2		61.24	15.87	88.90	25.4		52.58		6.93				47.50	
	2		48.77	12.70	88.90	28.5		40.89		6.35				47.50	
	2		42.67	12.70	88.90	30.1		34.92		6.07				47.50	
	2		33.91	12.70	88.90	31.7		26.67		5.69				47.50	
4 x 3 x 2-1/2 x 2 x 1-1/2 x 1-1/4	2		89.99	15.87	114.30	33.2		77.99		9.52				60.32	
	2		74.01	15.87	114.30	38.1		62.74		8.76				60.32	
	2		61.24	15.87	114.30	38.1		52.58		6.93				60.32	
	2		48.77	12.70	114.30	41.2		40.89		6.35				60.32	
	2		42.67	12.70	114.30	42.8		34.92		6.07				60.32	

(1) At the option of the manufacturer Type2 reducers may be furnished in Type1 configuration.

TOLERANCES

Laying Length A	Sizes 3/8" thru 3/4"	± 1.52mm	Bore D	Sizes 3/8" thru 2"	± 0.76mm
	Sizes 1" thru 2"	± 2.03mm		Sizes 2-1/2" thru 4"	± 1.52mm
	Sizes 2-1/2" thru 3/4"	± 0.13mm			
Socket Dia. B	Sizes 2" thru 3/4"	± 0.13mm	Shank Dia. SD	Sizes 1/4" thru 1-1/2"	± 0.25mm
	Sizes 2-1/2" thru 4"	± 0.20mm		Sizes 2" thru 3"	± 0.51mm
				Sizes 4"	± 0.76mm

Forged Steel Threaded Fittings

90° ELBOW

2000# 3000# 6000#

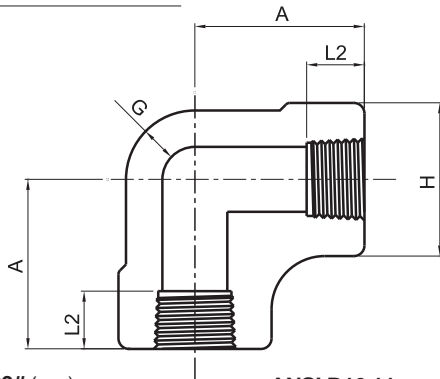

2000# (mm) ANSI B16.11

Pipe Size	A	H	G	L2
1/8	21	22	3.0	6.5
1/4	21	22	3.0	10.0
3/8	25	25	3.0	10.5
1/2	29	33	3.0	13.5
3/4	33	38	3.0	14.0
1	38	46	3.5	17.5
1-1/4	44	56	4.0	18.0
1-1/2	51	62	4.0	18.5
2	60	75	4.5	19.0
2-1/2	76	92	5.5	29.0
3	86	110	6.0	30.5
4	106	146	6.5	33.0

3000# (mm) ANSI B16.11

Pipe Size	A	H	G	L2
1/8	21	22	3.0	6.5
1/4	25	25	3.5	10.0
3/8	29	33	3.5	10.5
1/2	33	38	4.0	13.5
3/4	38	46	4.5	14.0
1	44	56	5.0	17.5
1-1/4	51	62	5.5	18.0
1-1/2	60	75	5.5	18.5
2	64	84	7.0	19.0
2-1/2	83	102	7.5	29.0
3	95	121	9.0	30.5
4	114	152	11.0	33.0

6000# (mm) ANSI B16.11

Pipe Size	A	H	G	L2
1/8	25	25	6.5	6.5
1/4	29	33	6.5	10.0
3/8	33	38	7.0	10.5
1/2	38	46	8.0	13.5
3/4	44	56	8.5	14.0
1	51	62	10.0	17.5
1-1/4	60	75	10.5	18.0
1-1/2	64	84	11.0	18.5
2	83	102	12.0	19.0
2-1/2	95	121	15.5	29.0
3	106	146	16.5	30.5
4	114	152	18.5	33.0

45° ELBOW

2000# 3000# 6000#

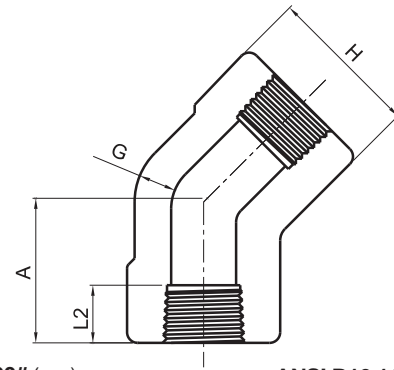

2000# (mm) ANSI B16.11

Pipe Size	A	H	G	L2
1/8	17	22	3.0	6.5
1/4	17	22	3.0	10.0
3/8	19	25	3.0	10.5
1/2	22	33	3.0	13.5
3/4	25	38	3.0	14.0
1	29	46	3.5	17.5
1-1/4	33	56	4.0	18.0
1-1/2	35	62	4.0	18.5
2	43	75	4.5	19.0
2-1/2	52	92	5.5	29.0
3	64	110	6.0	30.5
4	79	146	6.5	33.0

3000# (mm) ANSI B16.11

Pipe Size	A	H	G	L2
1/8	17	22	3.0	6.5
1/4	19	25	3.5	10.0
3/8	22	33	3.5	10.5
1/2	25	38	4.0	13.5
3/4	29	46	4.5	14.0
1	33	56	5.0	17.5
1-1/4	35	62	5.5	18.0
1-1/2	43	75	5.5	18.5
2	45	84	7.0	19.0
2-1/2	52	102	7.5	29.0
3	64	121	9.0	30.5
4	79	152	11.0	33.0

6000# (mm) ANSI B16.11

Pipe Size	A	H	G	L2
1/8	19	25	6.5	6.5
1/4	22	33	6.5	10.0
3/8	25	38	7.0	10.5
1/2	29	46	8.0	13.5
3/4	33	56	8.5	14.0
1	35	62	10.0	17.5
1-1/4	43	75	10.5	18.0
1-1/2	44	84	11.0	18.5
2	52	102	12.0	19.0
2-1/2	64	121	15.5	29.0
3	79	146	16.5	30.5
4	79	152	18.5	33.0

Forged Steel Threaded Fittings

TEE

2000# 3000# 6000#

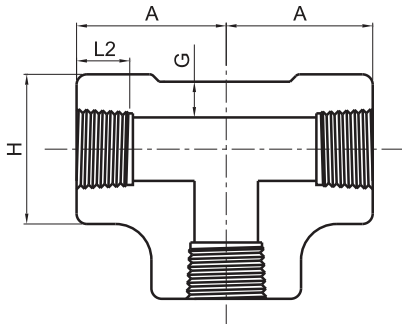

2000# (mm) ANSI B16.11

Pipe Size	A	H	G	L2
1/8	21	22	3.0	6.5
1/4	21	22	3.0	10.0
3/8	25	25	3.0	10.5
1/2	29	33	3.0	13.5
3/4	33	38	3.0	14.0
1	38	46	3.5	17.5
1-1/4	44	56	4.0	18.0
1-1/2	51	62	4.0	18.5
2	60	75	4.5	19.0
2-1/2	76	92	5.5	29.0
3	86	110	6.0	30.5
4	106	146	6.5	33.0

3000# (mm) ANSI B16.11

Pipe Size	A	H	G	L2
1/8	21	22	3.0	6.5
1/4	25	25	3.5	10.0
3/8	29	33	3.5	10.5
1/2	33	38	4.0	13.5
3/4	38	46	4.5	14.0
1	44	56	5.0	17.5
1-1/4	51	62	5.5	18.0
1-1/2	60	75	5.5	18.5
2	64	84	7.0	19.0
2-1/2	83	102	7.5	29.0
3	95	121	9.0	30.5
4	114	152	11.0	33.0

6000# (mm) ANSI B16.11

Pipe Size	A	H	G	L2
1/8	25	25	6.5	6.5
1/4	29	33	6.5	10.0
3/8	33	38	7.0	10.5
1/2	38	46	8.0	13.5
3/4	44	56	8.5	14.0
1	51	62	10.0	17.5
1-1/4	60	75	10.5	18.0
1-1/2	64	84	11.0	18.5
2	83	102	12.0	19.0
2-1/2	95	121	15.5	29.0
3	106	146	16.5	30.5
4	114	152	18.5	33.0

CROSS

2000# 3000# 6000#

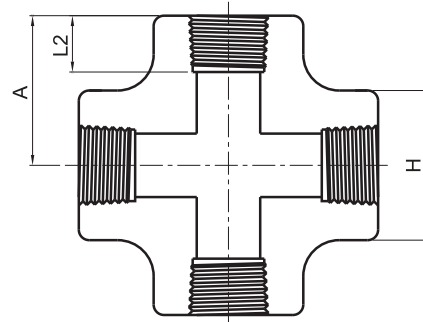

2000# (mm) ANSI B16.11

Pipe Size	A	H	L2
1/8	21	22	6.5
1/4	21	22	10.0
3/8	25	25	10.5
1/2	29	33	13.5
3/4	33	38	14.0
1	38	46	17.5
1-1/4	44	56	18.0
1-1/2	51	62	18.5
2	60	75	19.0
2-1/2	76	92	29.0
3	86	110	30.5
4	106	146	33.0

3000# (mm) ANSI B16.11

Pipe Size	A	H	L2
1/8	21	22	6.5
1/4	25	25	10.0
3/8	29	33	10.5
1/2	33	38	13.5
3/4	38	46	14.0
1	44	56	17.5
1-1/4	51	62	18.0
1-1/2	60	75	18.5
2	64	84	19.0
2-1/2	83	102	29.0
3	95	121	30.5
4	114	152	33.0

6000# (mm) ANSI B16.11

Pipe Size	A	H	L2
1/8	25	25	6.5
1/4	29	33	10.0
3/8	33	38	10.5
1/2	38	46	13.5
3/4	44	56	14.0
1	51	62	17.5
1-1/4	60	75	18.0
1-1/2	64	84	18.5
2	83	102	19.0
2-1/2	95	121	29.0
3	106	146	30.5
4	114	152	33.0

Forged Steel Threaded Fittings

FULL COUPLING

3000# 6000#

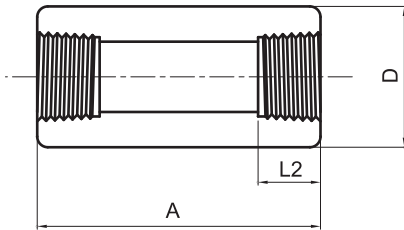

3000# (mm) ANSI B16.11

Pipe Size	A	D	L2
1/8	32	16	6.5
1/4	35	19	10.0
3/8	38	22	10.5
1/2	48	29	13.5
3/4	51	35	14.0
1	60	44	17.5
1-1/4	67	57	18.0
1-1/2	79	64	18.5
2	86	76	19.0
2-1/2	92	92	29.0
3	108	108	30.5
4	121	140	33.0

6000# (mm) ANSI B16.11

Pipe Size	A	D	L2
1/8	32	22	6.5
1/4	35	25	10.0
3/8	38	32	10.5
1/2	48	38	13.5
3/4	51	44	14.0
1	60	57	17.5
1-1/4	67	64	18.0
1-1/2	79	76	18.5
2	86	92	19.0
2-1/2	92	108	29.0
3	108	127	30.5
4	121	159	33.0

HALF COUPLING

3000# 6000#

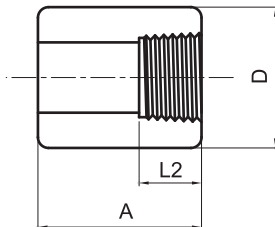

3000# (mm) ANSI B16.11

Pipe Size	A	D	L2
1/8	16	16	6.5
1/4	17.5	19	10.0
3/8	19	22	10.5
1/2	24	29	13.5
3/4	25.5	35	14.0
1	30	44	17.5
1-1/4	33.5	57	18.0
1-1/2	39.5	64	18.5
2	43	76	19.0
2-1/2	46	92	29.0
3	54	108	30.5
4	60.5	140	33.0

6000# (mm) ANSI B16.11

Pipe Size	A	D	L2
1/8	16	22	6.5
1/4	17.5	25	10.0
3/8	19	32	10.5
1/2	24	38	13.5
3/4	25.5	44	14.0
1	30	57	17.5
1-1/4	33.5	64	18.0
1-1/2	39.5	76	18.5
2	43	92	19.0
2-1/2	46	108	29.0
3	54	127	30.5
4	60.5	159	33.0

CAP

3000# 6000#

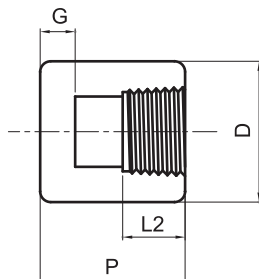

3000# (mm) ANSI B16.11

Pipe Size	P	D	L2	G
1/8	19	16	6.5	5.0
1/4	25	19	10.0	5.0
3/8	25	22	10.5	5.0
1/2	32	29	13.5	6.5
3/4	37	35	14.0	6.5
1	41	44	17.5	9.5
1-1/4	44	57	18.0	9.5
1-1/2	44	64	18.5	11.0
2	48	76	19.0	12.5
2-1/2	60	92	29.0	16.0
3	65	108	30.5	19.0
4	68	140	33.0	22.0

6000# (mm) ANSI B16.11

Pipe Size	P	D	L2	G
1/4	27	25	10.0	6.5
3/8	27	32	10.5	6.5
1/2	33	38	13.5	8.0
3/4	38	44	14.0	8.0
1	43	57	17.5	11.0
1-1/4	46	64	18.0	11.0
1-1/2	48	76	18.5	12.5
2	51	92	19.0	16.0
2-1/2	64	108	29.0	19.0
3	68	127	30.5	22.0
4	75	159	33.0	28.5

Forged Steel Threaded Fittings

HEX HEAD PLUG

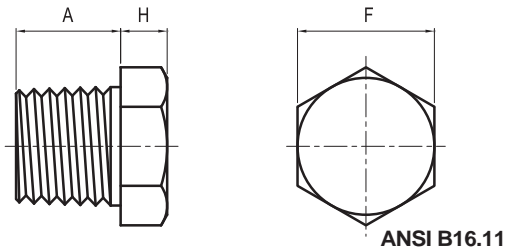

Nominal Pipe Size	Length (Minimum) A	Hex Height Min. H	Width Flats (Nominal) F	Unit Weight (kg)
1/8	9.5	6	11.0	0.03
1/4	11.0	6	16.0	0.03
3/8	12.5	8	17.5	0.06
1/2	14.5	8	22.0	0.09
3/4	16.0	10	27.0	0.14
1	19.0	10	35.0	0.23
1 1/4	20.5	14	44.5	0.51
1 1/2	20.5	16	51.0	0.63
2	22.0	17	63.5	1.02
2 1/2	27.0	19	76.0	1.76
3	28.5	21	89.0	2.67
4	32.0	25	117.5	5.90

HEX HEAD BUSHING

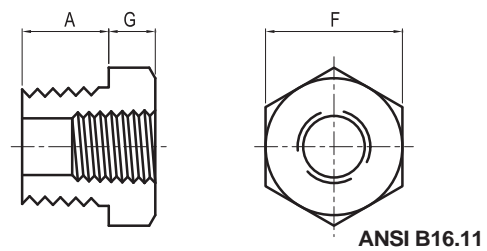

Nominal Pipe Size	Length (Minimum) A	Hex Height Min. G	Width Flats (Nominal) F	Unit Weight (kg)
1/4	11.0	3	16.0	0.03
3/8	12.5	4	17.5	0.03
1/2	14.5	5	22.0	0.03
3/4	16.0	6	27.0	0.09
1	19.0	6	35.0	0.09
1 1/4	20.5	7	44.5	0.17
1 1/2	20.5	8	51.0	0.31
2	22.0	9	63.5	0.74
2 1/2	27.0	10	76.0	1.08
3	28.5	10	89.0	1.59
4	32.0	13	117.5	3.77

SQUARE HEAD PLUG

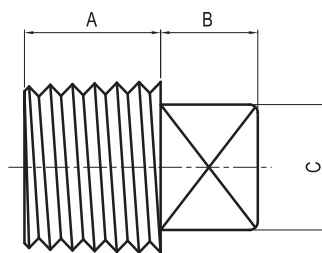

Nominal Pipe Size	Length (Minimum) A	Height of Square (Minimum) B	Width Flats (Minimum) C	Unit Weight (kg)
1/8	9.5	6	7.0	0.01
1/4	11.0	6	9.5	0.01
3/8	12.5	8	11.0	0.03
1/2	14.5	10	14.5	0.06
3/4	16.0	11	16.0	0.09
1	19.0	13	20.5	0.14
1 1/4	20.5	14	24.0	0.25
1 1/2	20.5	16	28.5	0.40
2	22.0	17	33.5	0.68
2 1/2	27.0	19	38.0	1.02
3	28.5	21	43.0	1.31
4	32.0	25	63.5	3.26

ROUND HEAD PLUG

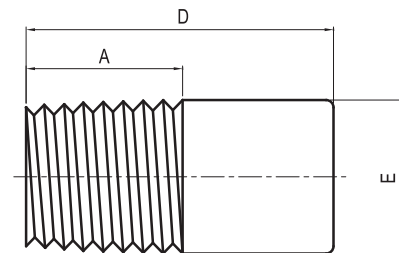

Nominal Pipe Size	Length (Minimum) A	Nominal Diameter of Head E	Length (Minimum) D	Unit Weight (kg)
1/8	9.5	10	35	0.057
1/4	11.0	13	41	0.057
3/8	12.5	17	41	0.085
1/2	14.5	21	44	0.170
3/4	16.0	27	44	0.170
1	19.0	33	51	0.340
1 1/4	20.5	43	51	0.340
1 1/2	20.5	48	51	0.710
2	22.0	60	64	1.361
2 1/2	27.0	73	70	2.155
3	28.5	89	70	3.456
4	32.0	114	76	5.838

Forged Steel Threaded Fittings

UNION

3000#

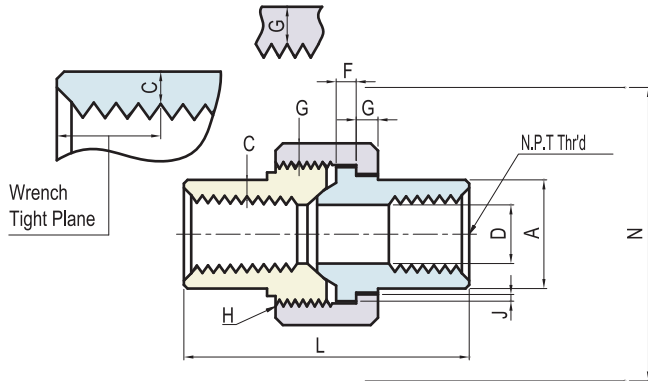

MSS SP-83

(mm)

Nom. Pipe Size	Pipe End Min. A	Wall Min. C	Water Way Bore D	Male Flange Min. F	Nut Min. G	Thrds. Per 25.4 Max. H	Bearing Min. J	Length Assem. Nominal L	Clear Assem. Nut N
1/8	14.7	2.41	6.83 6.43	3.17	3.2	16	1.24	41.4	49.0
1/4	19.0	3.02	9.85 9.45	3.17	3.2	16	1.24	41.4	49.0
3/8	22.9	3.20	13.92 13.51	3.43	3.4	14	1.37	46.0	55.0
1/2	27.7	3.73	17.47 17.07	3.68	3.7	14	1.50	49.0	57.0
3/4	33.5	3.91	21.79 21.39	4.06	4.1	11	1.68	56.9	67.0
1	41.4	4.55	28.14 27.74	4.57	4.4	11	1.85	62.0	79.0
1 1/4	50.5	4.85	35.76 35.36	5.33	5.2	11	2.13	71.1	94.0
1 1/2	57.2	5.08	41.61 41.20	5.84	5.6	10	2.31	76.4	111.0
2	70.1	5.54	52.53 52.12	6.60	6.4	10	2.69	86.1	132.0
2 1/2	85.3	7.01	64.72 64.31	7.49	7.1	8	3.07	102.4	148.0
3	102.4	7.62	77.67 77.27	8.25	8.0	8	3.53	109.0	175.0

UNION

3000# 6000#

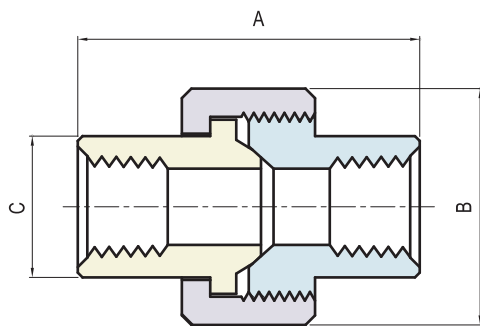

STANDARD

(mm)

Nom. Size	A		B		C		Unit Weight (kg)	
	3000	6000	3000	6000	3000	6000	3000	6000
1/4	45	54	32	46	19	30	0.14	0.45
3/8	51	57	38	51	23	36	0.20	0.60
1/2	54	64	46	60	29	43	0.35	0.85
3/4	57	72	51	72	34	52	0.43	1.40
1	69	80	60	80	41.5	59	0.65	1.75
1 1/4	72	89	72	94	48.8	74.5	0.98	3.00
1 1/2	80	108	80	100	56	77	1.26	4.00
2	89	114	94	120	70	90	2.01	5.50

UNION (O-RING TYPE)

3000#

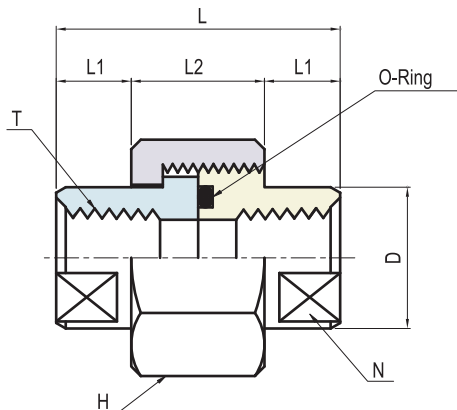

(mm)

Nom. Size (PT)	D	L1	L2	L	N	H	O-Ring
1/4	22	10	18	38	19	35 HEX	P18
3/8	27	10	18	38	23	41 HEX	P20
1/2	32	12	20	44	29	46 HEX	G25
3/4	38	12	26	50	34	54 HEX	G30
1	47	15	26	56	41	63 HEX	G35
1 1/4	56	15	30	60	51	75 HEX	G45
1 1/2	63	18	36	72	60	80 OCT	G50
2	76	18	36	72	71	95 OCT	G65

Rating Pressure: 210k/cm²

Temperature: 120°C Max.

Forged Steel Threaded Fittings

NIPPLE

3000# 6000#

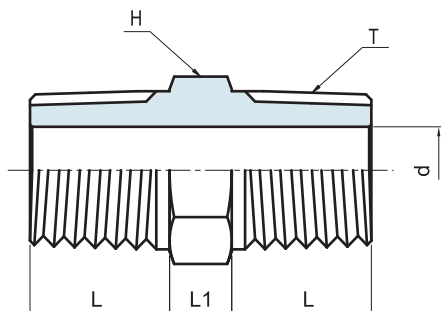

ANSI B16.11 (mm)

Nom Size T	d	*H	L	L1	Unit Weight (kg)
1/8	4.1	12	10	6	0.03
1/4	7.1	17	14	8	0.04
3/8	8.9	19	14	8	0.05
1/2	11.9	24	19	9	0.09
3/4	16.0	30	19	10	0.15
1	20.1	36	24	11	0.27
1 1/4	27.9	46	24	12	0.45
1 1/2	32.0	50	25	14	0.62
2	39.9	65	26	16	1.03
2 1/2	55.1	80	38	18	1.51
3	65.0	95	40	20	2.22

REDUCING NIPPLE

3000# 6000#

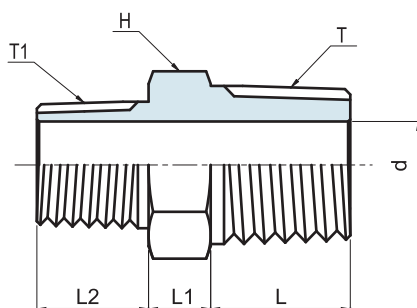

ANSI B16.11 (mm)

Nom Size T _x T ₁	d	*H	L	L1	L2	Unit Weight (kg)
3/8x1/4	7.1	19	14	8	14	0.05
1/2x1/4	7.1	24	19	9	14	0.09
1/2x3/8	8.9	24	19	9	14	0.09
3/4x1/4	7.1	30	19	10	14	0.15
3/4x3/8	8.9	30	19	10	14	0.15
3/4x1/2	11.9	30	19	10	19	0.15
1x3/8	8.9	36	24	11	14	0.27
1x1/2	11.9	36	24	11	19	0.27
1x3/4	16.0	36	24	11	19	0.27
1 1/4x1/2	11.9	46	24	12	19	0.45
1 1/4x3/4	16.0	46	24	12	19	0.45
1 1/4x1	20.1	46	24	12	24	0.45
1 1/2x3/4	16.0	50	25	14	19	0.62
1 1/2x1	20.1	50	25	14	24	0.62
1 1/2x1 1/4	27.9	50	25	14	24	0.62
2x1	20.1	65	26	16	24	1.03
2x1 1/4	27.9	65	26	16	24	1.03
2x1 1/2	32.0	65	26	16	25	1.03
2 1/2x1 1/4	27.9	80	38	18	24	1.51
2 1/2x1 1/2	32.0	80	38	18	25	1.51
2 1/2x2	39.9	80	38	18	26	1.51
3x1 1/2	32.0	95	40	20	25	2.22
3x2	39.9	95	40	20	26	2.22
3x2 1/2	55.1	95	40	20	38	2.22

* H: Size 2" and smaller are Hexagonal bodies, 3" is octagonal body

Forged Steel Threaded Fittings

BOSS

3000# 6000#

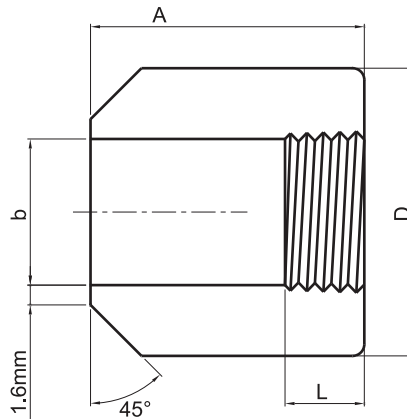

BS 3799

Nominal size		Length of thread L MIN (mm)	Length A (mm)	Bore dia b (mm)	Outside dia. D (mm)	
in	mm				3000	6000
1/8	6	6.70	38	8.4	16	22
1/4	8	10.21	41	11.1	19	26
3/8	10	10.36	45	14.2	22	32
1/2	15	13.56	51	18.0	29	38
3/4	20	13.86	51	23.0	35	45
1	25	17.34	51	29.0	45	60
1 1/2	40	18.38	51	44.0	64	76
2	50	19.22	51	56.0	76	95
2 1/2	65	28.89	51	67.0	95	-
3	80	30.48	57	82.0	110	-
4	100	33.02	64	95.0	140	-

SWAGED NIPPLE

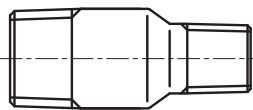

TBE

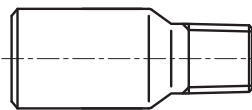

BLE/TSE

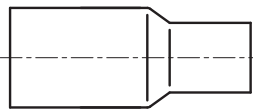

PBE

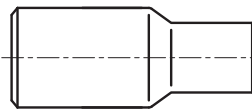

BLE/PSE

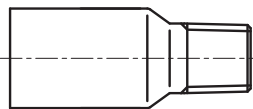

PLE/TSE

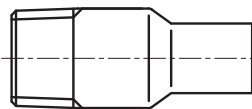

TLE/PSE

Large end Size	Small end Size	Length (mm)
1/2	3/8 - 1/8	70
3/4	1/2 - 1/8	76
1	3/4 - 1/8	89
1 1/4	1 - 1/8	102
1 1/2	1 1/4 - 1/8	114
2	1 1/2 - 1/8	165
2 1/2	2 - 1/8	178
3	2 1/2 - 1/8	203
3 1/2	3 - 1/8	203
4	3 1/2 - 1/8	229

TBE: Threaded both end

PBE: Plane both end

PLE/TSE: Plane large end-Thread small end

BLE/TSE: Beveled large end-Threaded small end

BLE/PSE: Beveled large end-Plane small end

TLE/PSE: Threaded large end-Plane small end

Forged Steel Outlet Fittings

NIPPLE OUTLET

3000#

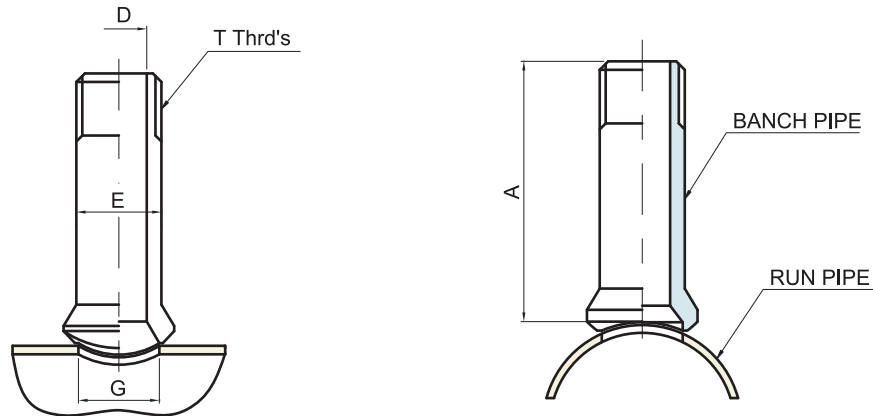

Run Pipe Size	Outlet Size T	A	G	D	E	Unit Weight (kg)
36- 3/4	1/2	88.9	23.9	14.0	21.3	0.36
36- 1	3/4	88.9	30.2	18.8	26.7	0.56
36- 1 1/4	1	88.9	36.6	24.4	33.3	0.84
36- 1 1/2	1 1/4	88.9	44.5	32.5	42.2	1.22
36- 2	1 1/2	88.9	50.8	38.1	48.3	2.00
36- 2 1/2	2	88.9	65.0	49.3	60.5	3.12

(mm)

FLANGED-END OUTLET

3000#

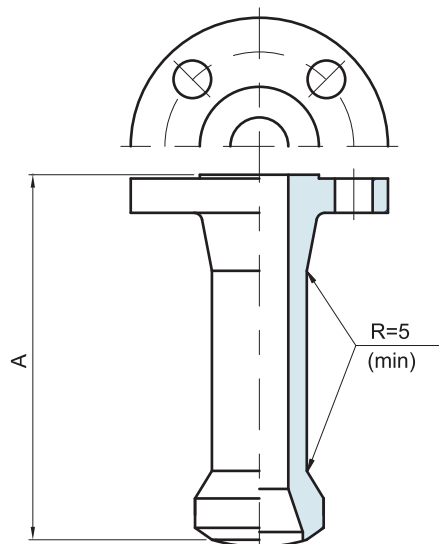

Nominal Size DN	A (Face of flange to crotch) Class				
	150	300	600	1500	2500
15	150	150	150	150	150
20					
25					
40					
50					165

(mm)

Forged Steel Outlet Fittings

WELDOLETS

STD (SCH 40), XS(SCH 80)

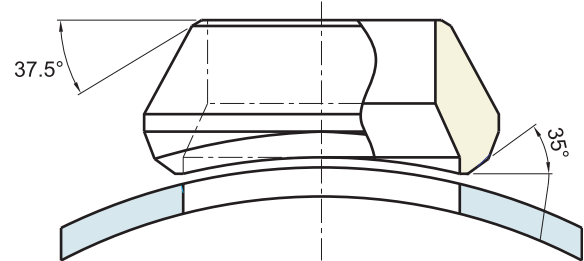
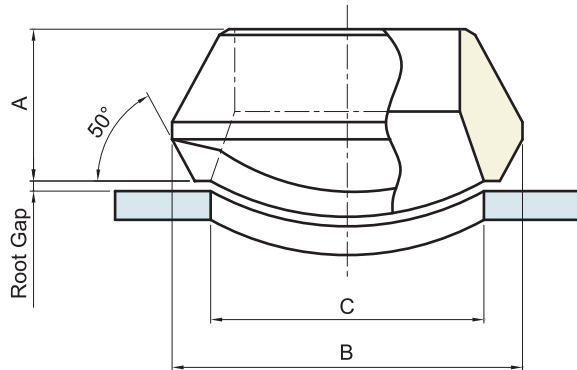

Out let Size	A		B		C		APP'Weight(kg)	
	STD	XS	STD	XS	STD	XS	STD	XS
1/2	19.1	19.1	34.9	34.9	23.8	23.8	0.08	0.09
3/4	22.2	22.2	44.5	44.5	30.2	30.2	0.11	0.14
1	27.0	27.0	54.0	54.0	36.5	36.5	0.23	0.21
1 1/4	31.8	31.8	65.1	65.1	44.5	44.5	0.36	0.41
1 1/2	33.3	33.3	73.0	73.0	50.8	50.8	0.45	0.5
2	38.1	38.1	88.9	88.9	65.1	65.1	0.80	0.80
2 1/2	41.3	41.3	103.2	103.2	76.2	76.2	1.14	1.2
3	44.5	44.5	122.2	122.2	93.7	93.7	1.82	1.9
4	50.8	50.8	152.4	152.4	120.7	120.7	2.86	2.9
5	57.2	57.2	179.4	179.4	141.3	141.3	4.66	4.7
6	60.3	77.8	215.9	225.4	169.9	169.9	6.45	10.5
8	69.9	98.5	263.5	292.1	220.7	220.7	10.68	16.8
10	77.8	93.7	322.3	323.9	274.7	265.1	17.73	20.9
12	85.7	103.2	377.8	379.4	325.4	317.5	26.82	27.7
14	88.9	100.0	409.6	431.8	357.2	350.8	30.0	31.8
16	93.7	106.4	463.6	466.7	408.0	403.2	34.1	46.4
18	96.8	111.1	520.7	523.9	458.8	455.6	44.1	59.1
20	101.6	119.1	571.5	582.6	508.0	509.6	53.6	71.8
24	115.9	139.7	689.0	708.0	614.4	638.2	100.0	131.8
26	119.1	146.1	738.2	765.2	666.8	692.2	120.5	159.1

* Applicable Run Pipe Sizes are from Out-let size to 36"

* Standard Weight Fittings are the same as Schedule 40 Fittings Until 10" and Extra Strong Fittings are the Same as Schedule 80 Until 8".

* Pipe Schedule Numbers and Weight Designations are in Accordance With ANSI B36.10

Forged Steel Outlet Fittings

SOCKOLETS

3000# 6000#

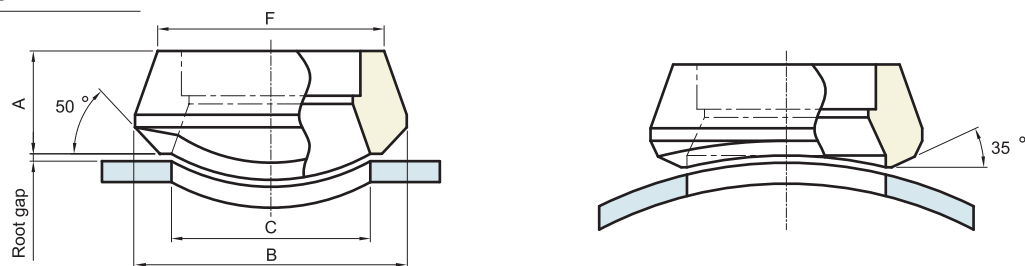

Out let Size	A		B		C		F		APP'Weight (kg)	
	3000#	6000#	3000#	6000#	3000#	6000#	3000#	6000#	3000#	6000#
1/2	25.4	31.8	34.9	44.5	23.8	19.1	31.8	39.7	0.14	0.23
3/4	27.0	36.5	44.5	50.8	30.2	25.4	36.5	45.2	0.15	0.36
1	33.3	39.7	54.0	61.9	36.5	33.3	46.0	57.2	0.27	0.59
1 1/4	33.3	41.3	65.1	69.9	44.5	38.1	55.6	65.1	0.39	0.73
1 1/2	34.9	42.9	73.0	82.6	50.8	49.2	61.9	76.2	0.47	0.91
2	38.1	58.7	88.9	103.2	65.1	58.7	74.6	92.1	0.73	2.33
2 1/2	46.0	-	103.2	-	76.2	-	87.3	-	1.25	-
3	50.8	-	122.2	-	93.7	-	104.8	-	1.73	-
4	57.2	-	152.4	-	120.7	-	130.2	-	3.3	-

* Applicable Run Pipe Sizes are from Out-let size to 36"

* For the 3000# and 6000# Socketlets and Thredolets, Inside Bore, Thread, Socket Bore and socket Depth Dimensions are According to ANSI B16.11

* Pipe Schedule Numbers and Weight Designations are in Accordance With ANSI B36.10

THREDOLETS

3000# 6000#

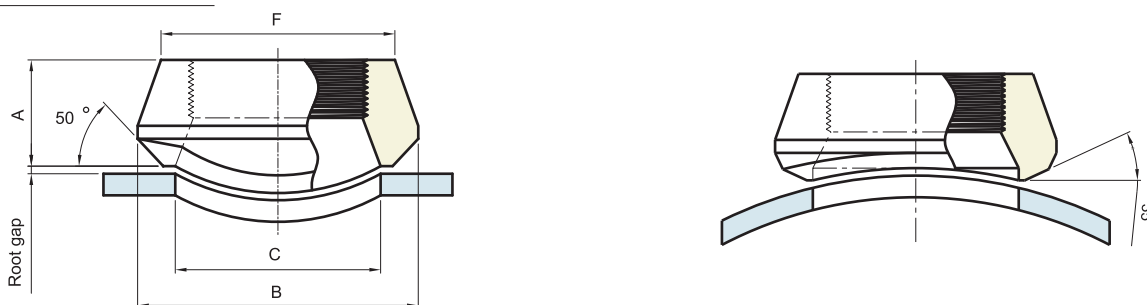

Out let Size	A		B		C		F		APP'Weight (kg)	
	3000#	6000#	3000#	6000#	3000#	6000#	3000#	6000#	3000#	6000#
1/2	25.4	31.8	34.9	44.5	23.8	19.1	31.8	39.7	0.11	0.20
3/4	27.0	36.5	44.5	50.8	30.2	25.4	36.5	46.0	0.16	0.34
1	33.3	39.7	54.0	61.9	36.5	33.3	46.0	57.2	0.28	0.56
1 1/4	33.3	41.3	65.1	69.9	44.5	38.1	55.6	65.1	0.41	0.71
1 1/2	34.9	42.9	73.0	82.6	50.8	49.2	61.9	76.2	0.45	0.89
2	38.1	52.4	88.9	103.2	65.1	69.9	74.6	92.1	0.8	2.30
2 1/2	46.0	-	103.2	-	76.2	-	87.3	-	1.36	-
3	50.8	-	122.2	-	93.7	-	104.8	-	1.98	-
4	57.2	-	152.4	-	120.7	-	130.2	-	3.22	-

* Applicable Run Pipe Sizes are from Out-let size to 36"

* For the 3000# and 6000# Socketlets and Thredolets, Inside Bore, Thread, Socket Bore and socket Depth Dimensions are According to ANSI B16.11

* Pipe Schedule Numbers and Weight Designations are in Accordance With ANSI B36.10

Standard Threads Specifications

KS BO222 & JIS BO203 PIPE THREADS

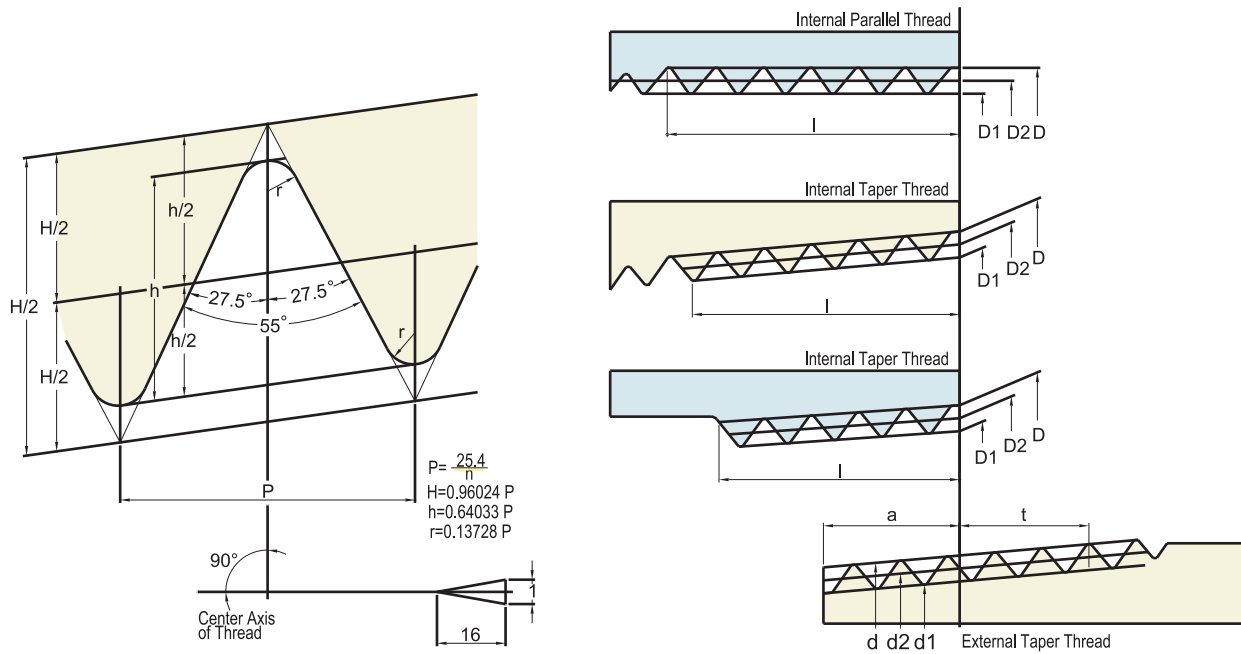

BASIC THREAD DATA

(mm)

Nominal Size	Screw Thread				Basic Diameter			Position of Basic Diameter			Tolerances on Basic Diameters of Internal Parallel Thread	Effective Thread Length (Min.)				Nominal Pipe Size (For Reference)	
	Number of Threads Per Inch	Pitch	Height of Thread	Rounding	External Thread			External Thread	Internal Thread			Fitting Allowance	Internal Thread				
					Major Diameter d	Pitch Diameter d2	Minor Diameter d1	From the End of Pipe	The End of Pipe				When There is an Incomplete Thread or More	When There is no Incomplete Thread			
	n	p	h	r	Internal Thread			Basic Length	Tolerance Axially	Tolerance Axially		±	Internal Taper Thread	Internal Parallel Thread	Internal Taper and Parallel Thread	Outside Diameter	Wall Thickness
					Major Diameter	Pitch Diameter	Minor Diameter										
PT 1/2	14	1.8143	1.162	0.25	20.955	19.793	18.631	8.16	1.81	2.27	0.142	5.00	12.7	15.0	9.1	21.7	2.8
PT 3/4	14	1.8143	1.162	0.25	26.441	25.279	24.117	9.53	1.81	2.27	0.142	5.60	14.1	16.3	10.2	27.2	2.8
PT 1	11	2.3091	1.479	0.32	33.249	31.770	30.291	10.39	2.31	2.89	0.180	6.40	16.2	19.0	11.5	34.0	3.2
PT 1 1/4	11	2.3091	1.479	0.32	41.910	40.431	38.952	12.70	2.31	2.89	0.180	6.40	18.5	21.4	13.4	42.7	3.5
PT 1 1/2	11	2.3091	1.479	0.32	47.803	46.324	44.845	12.70	2.31	2.89	0.180	6.40	18.5	21.4	13.4	48.6	3.5
PT 2	11	2.3091	1.479	0.32	59.614	58.135	56.656	15.88	2.31	2.89	0.180	7.50	22.8	25.7	16.9	60.5	3.8
PT 2 1/2	11	2.3091	1.479	0.32	75.184	73.705	72.226	17.46	3.56	3.46	0.217	9.22	26.7	30.2	18.6	76.3	4.2
PT 3	11	2.3091	1.479	0.32	87.884	86.405	84.926	20.64	3.46	3.46	0.217	9.22	29.9	33.3	21.1	89.1	4.2
PT 3 1/2	11	2.3091	1.479	0.32	100.330	98.851	97.372	22.23	3.46	3.46	0.217	9.30	31.5	34.9	22.4	101.6	4.2
PT 4	11	2.3091	1.479	0.32	113.030	111.551	110.072	25.40	3.46	3.46	0.217	10.40	35.9	39.3	25.9	114.3	4.5
PT 5	11	2.3091	1.479	0.32	138.430	136.952	135.472	25.58	3.46	3.46	0.217	11.40	40.1	43.6	29.3	139.8	4.5
PT 6	11	2.3091	1.479	0.32	163.830	162.351	160.872	28.58	3.46	3.46	0.217	11.50	40.1	43.6	29.3	165.2	5.0

Standard Threads Specifications

ANSI B2.1 TAPER PIPE THREADS.(EXCEPT DRYSEAL)

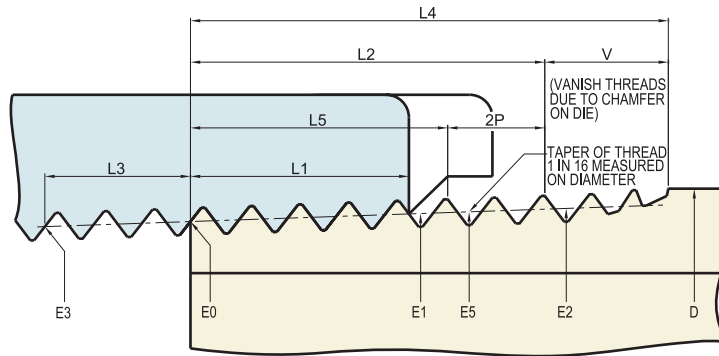

Taper 1 in 16 on Diameter
(Shown Exaggerated in Diagram)

THREAD HEIGHT DIMENSIONS

Thread Element	27 Threads Per inch P=0.03704	18 Threads Per inch P=0.05556	14 Threads Per inch P=0.07143	11 1/2 Threads Per inch P=0.08696	8 Threads Per inch P=0.12500
H=0.866p	0.0321	0.4810	0.0619	0.0753	0.1082
hs=hn=0.760p	0.0281	0.0422	0.0543	0.0661	0.0950
frs=frn=0.033p	0.0012	0.0088	0.0024	0.0029	0.0041
fcs=fcn=0.073p	0.0027	0.0041	0.0052	0.0063	0.0091

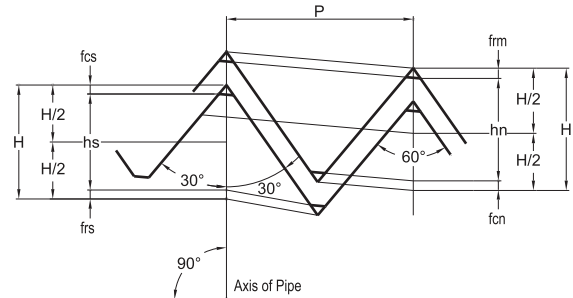

BASIC THREAD DATA

(inch)

Nominal Pipe Size (NPT)	Outside Diameter of Pipe D	Threads Per inch n	Pitch of Thread P	Pitch Diameter at beginning of External Thread E0	Handtight Engagement			Effective Thread, External		
					Length L1		Dia E1	Length L2		Dia E2
					In.	Thds.		In.	Thds.	
1	2	3	4	5	6	7	8	9	10	11
1/8	0.405	27.0	0.03704	0.36351	0.1615	4.36	0.37360	0.2639	7.12	0.38000
1/4	0.540	18.0	0.05556	0.47739	0.2278	4.10	0.49163	0.4018	7.23	0.50250
3/8	0.675	18.0	0.05556	0.61201	0.2400	4.32	0.62701	0.4078	7.34	0.63750
1/2	0.840	14.0	0.07143	0.75843	0.3200	4.48	0.77843	0.5337	7.47	0.79179
3/4	1.050	14.0	0.07143	0.96768	0.3390	4.75	0.98887	0.5457	7.64	1.00179
1	1.315	11.5	0.08696	1.21363	0.4000	4.60	1.23863	0.6828	7.85	1.25630
1 1/4	1.660	11.5	0.08696	1.55713	0.4200	4.83	1.58338	0.7068	8.13	1.60130
1 1/2	1.900	11.5	0.08696	1.79609	0.4200	4.83	1.82234	0.7235	8.32	1.84130
2	2.375	11.5	0.08696	2.26902	0.4360	5.01	2.29627	0.7565	8.70	2.31630
2 1/2	2.875	8.0	0.12500	2.71953	0.6820	5.46	2.76216	1.1375	9.10	2.79062
3	3.500	8.0	0.12500	3.34062	0.7660	6.13	3.38850	1.2000	9.60	3.41562
3 1/2	4.000	8.0	0.12500	3.83750	0.8210	6.57	3.88881	1.2500	10.00	3.91562
4	4.500	8.0	0.12500	4.33438	0.8440	6.75	4.38712	1.3000	10.40	4.41562

Nominal Pipe Size (NPT)	Wrench, Makeup Length for External Thread L2 - L1		Wrench Makeup Length for Internal Thread			Vanish Thread V		Overall Length External Thread L4	Nominal, Completes External Threads*		Height of Thread h	Increase in Dia per Thread, 0.0625/n	Basic Minor Dia at Small End of Pipe, ko
	In.	Thds.	Length L3		Dia E3	In.	Thds.		Length L5	Dia, E5			
			In.	Thds.									
1	12	13	14	15	16	17	18	19	20	21	22	23	24
1/8	0.1024	2.76	0.1111	3	0.35656	0.1285	3.47	0.3924	0.1898	0.37537	0.02963	0.00231	0.3339
1/4	0.1740	3.13	0.1667	3	0.46697	0.1928	3.47	0.5946	0.2907	0.49556	0.04444	0.00347	0.4329
3/8	0.1678	3.02	0.1667	3	0.60160	0.1928	3.47	0.6006	0.2967	0.63056	0.04444	0.00347	0.5676
1/2	0.2137	2.99	0.2143	3	0.74504	0.2478	3.47	0.7815	0.3909	0.78286	0.05714	0.00446	0.7013
3/4	0.2067	2.89	0.2143	3	0.95429	0.2478	3.47	0.7935	0.4029	0.99286	0.05714	0.00446	0.9105
1	0.2828	3.25	0.2609	3	1.19733	0.3017	3.47	0.9845	0.5089	1.24543	0.06957	0.00543	1.1441
1 1/4	0.2868	3.30	0.2609	3	1.54083	0.3017	3.47	1.0085	0.5329	1.59043	0.06957	0.00543	1.4876
1 1/2	0.3035	3.49	0.2609	3	1.77978	0.3017	3.47	1.0252	0.5496	1.83043	0.06957	0.00543	1.7265
2	0.3205	3.69	0.2609	3	2.25272	0.3017	3.47	1.0582	0.5826	2.30543	0.06957	0.00543	2.1995
2 1/2	0.4555	3.64	0.2500	2	2.70391	0.4337	3.47	1.5712	0.8875	2.77500	0.10000	0.00781	2.6195
3	0.4340	3.47	0.2500	2	3.32500	0.4337	3.47	1.6337	0.9500	3.40000	0.10000	0.00781	3.2406
3 1/2	0.4290	3.43	0.2500	2	3.82188	0.4337	3.47	1.6337	1.0000	3.90000	0.10000	0.00781	3.7375
4	0.4560	3.65	0.2500	2	4.31875	0.4337	3.47	1.7337	1.0500	4.40000	0.10000	0.00781	4.2344

Comparison of ASTM Specifications and Similar Standards

Steel Composition	ASTM Specification and Grade				KS Specification and Grade		
	Marking Symbol	Pipe	Plate	Forging	Marking Symbol	Pipe	Plate
Carbon Steel	-	A120	A283-A	-	SPP	SPP	SB41
	-	A53-B	A284	-	PS38(W),PS38,PT38(W),PT38	SPPS38	SWS41B
	-	A53-B	A284	-	PS42(W),PS42,PT42(W),PT42	SPPS42	SWS41B
					HT38,HT38(W)	SPHT38	SBB42
	WPB	A106-B	A515-60 or 70 A516-60 or 70	A105	HT42,HT42(W)	SPHT42	SBB42
	WPC	A106-C	A515-70 A516-70	A105	HT49,HT49(W)	SPHT49	SBB49
Low Temperature Steel	WPL6	A333/A334-6	A516-60	A350-LF2	PL39	STPL39	SLAL39
	WPL3	A333/A334-3	A203-D	A350-LF3	-	-	-
	WPL9	A333/A334-9	A203-A	A350-LF9	-	-	-
Alloy Steel	WP1	A335-P1	A204-B	A182-F1	PA12,FA12	SPA12	SBB46M
	WP12	A335-P12	A387-12	A182-F12	PA22,FA22	SPA22	SCMV2
	WP11	A335-P11	A387-11	A182-F11	PA23,FA23	SPA23	SCMV3
	WP22	A335-P22	A387-22	A182-F22	PA24,FA24	SPA24	SCMV4
	WP5	A335-P5	A387-5	A182-F5	PA25,FA25	SPA25	SCMV5
	WP7	A335-P7	A387-7	A182-F7	-	-	-
	WP9	A335-P9	A387-9	A182-F9	-	-	-
	WP91	A335-P91	A387-91	A182-F91	-	-	-
Stainless Steel	WP304	A312-TP304	A240-Type 304	A182-F304	STS304,STS304W,STS304F	STS304TP	STS304
	WP304H	A312-TP304H	A240-Type 304H	A182-F304H	-	-	-
	WP304L	A312-TP304L	A240-Type 304L	A182-F304L	STS304L,STS304LW,STS304LF	STS304LTP	STS304L
	WP309	A312-TP309	A240-Type 309S	-	STS309S,STS309SW,STS309SF	STS309STP	STS309S
	WP310	A312-TP310	A240-Type 310S	A182-F310	STS310S,STS310SW,STS310SF	STS310STP	STS310S
	WP316	A312-TP316	A240-Type 316	A182-F316	STS316,STS316W,STS316F	STS316TP	STS316
	WP316H	A312-TP316H	A240-Type 316H	A182-F316H	STS316H,STS316HF	STS316HTP	-
	WP316L	A312-TP316L	A240-Type 316L	A182-F316L	STS316L,STS316LW,STS316LF	STS316LTP	STS316L
	WP317L	A312-TP317L	A240-Type 317L	A182-F317L	STS317L,STS317LW	STS317LTP	STS317L
	WP321	A312-TP321	A240-Type 321	A182-F321	STS321,STS321W,STS321F	STS321TP	STS321
	WP321H	A312-TP321H	A240-Type 321H	A182-F321H	-	-	-
	WP347	A312-TP347	A240-Type 347	A182-F347	STS347,STS347W,STS347F	STS347TP	STS347
WP347H	A312-TP347H	A240-Type 347H	A182-F347H	STS347H,STS347HF	STS347HTP	-	

ASTM Chemical Composition

ASTM	Identification Symbol	C	Mn	P	S	Si	Ni	Cr	Mo	Ti	Other Elements	TS Min ksi(Mpa)	YS Min ksi(Mpa)	EL Min. %	Red Min. %	HB
A105*		MAX 0.35	0.60~1.05	MAX 0.035	MAX 0.040	0.10~0.35	MAX 0.40	MAX 0.30	MAX 0.12			70(485)	36(250)	30	30	MAX 187
A182	F1	0.28	0.60~0.90	0.045	0.045	0.15~0.35			0.44~0.65			70(485)	40(275)	20	30	143~192
A182	F5	0.15	0.30~0.60	0.030	0.030	0.50	0.50	4.0~6.0	0.44~0.65			70(485)	40(275)	20	35	143~217
A182	F5a	0.25	0.60	0.040	0.030	0.50	0.50	4.0~6.0	0.44~0.65			90(620)	65(450)	22	50	187~248
A182	F9	0.15	0.30~0.60	0.030	0.030	0.50~1.00		8.0~10.0	0.90~1.10			85(585)	55(380)	20	40	179~217
A182**	F91	0.08~0.12	0.30~0.60	0.020	0.010	0.20~0.50	0.40	8.0~9.5	0.85~1.05			85(585)	60(415)	20	40	MAX 248
A182	F11 CL1	0.05~0.15	0.30~0.60	0.030	0.030	0.50~1.00		1.00~1.50	0.44~0.65			60(415)	30(205)	20	45	121~174
A182	F11 CL2	0.10~0.20	0.30~0.80	0.040	0.040	0.50~1.00		1.00~1.50	0.44~0.65			70(485)	40(275)	20	30	143~207
A182	F11 CL3	0.10~0.20	0.30~0.80	0.040	0.040	0.50~1.00		1.00~1.50	0.44~0.65			75(515)	45(310)	20	30	156~207
A182	F12 CL1	0.05~0.15	0.30~0.60	0.045	0.045	MAX 0.50		0.80~1.25	0.44~0.65			60(415)	32(220)	20	45	121~174
A182	F12 CL2	0.10~0.20	0.30~0.80	0.040	0.040	0.10~0.60		0.80~1.25	0.44~0.65			70(485)	40(275)	20	30	143~207
A182	F22 CL1	0.05~0.15	0.30~0.60	0.040	0.040	0.50		2.00~2.50	0.87~1.13			60(415)	30(205)	20	35	MAX 170
A182	F22 CL3	0.05~0.15	0.30~0.60	0.040	0.040	0.50		2.00~2.50	0.87~1.13			75(515)	45(310)	20	30	156~207
A182	F304	0.08	2.00	0.045	0.030	1.00	8.0~11.0	18.0~20.0				75(515)	30(205)	30	50	
A182	F304L	0.030	2.00	0.045	0.030	1.00	8.0~13.0	18.0~20.0				70(485)	25(170)	30	50	
A182	F316	0.08	2.00	0.045	0.030	1.00	10.0~14.0	16.0~18.0	2.00~3.00			75(515)	30(205)	30	50	
A182	F316L	0.030	2.00	0.045	0.030	1.00	10.0~15.0	16.0~18.0	2.00~3.00			70(485)	25(170)	30	50	
A182	F317	0.08	2.00	0.045	0.030	1.00	11.0~15.0	18.0~20.0	3.0~4.0			75(515)	30(205)	30	50	
A182	F317L	0.030	2.00	0.045	0.030	1.00	11.0~15.0	18.0~20.0				70(485)	25(170)	30	50	
A182	F321	0.08	2.00	0.045	0.030	1.00	9.0~12.0	17.0~19.0		Cx5~0.7		75(515)	30(205)	30	50	
A182	F321H	0.04~0.10	2.00	0.045	0.030	1.00	9.0~12.0	17.0~19.0		Cx4~0.7		75(515)	30(205)	30	50	
A182	F347	0.08	2.00	0.045	0.030	1.00	9.0~12.0	17.0~20.0			Cb-10xC-1.1	75(515)	30(205)	30	50	
A182	F347H	0.04~0.10	2.00	0.045	0.030	1.00	9.0~13.0	17.0~20.0			Cb-8xC-1.1	75(515)	30(205)	30	50	
A182	F51	0.03	2.00	0.030	0.020	1.00	4.5~6.5	21.0~23.0	2.5~3.5		N 0.08~0.20	90(620)	65(450)	25	45	
A350*	LF1	0.30	0.60~1.35	0.035	0.040	0.15~0.30	MAX 0.40	MAX 0.30	MAX 0.12			60 ~ 85 (415 ~ 585)	30(205)	25	38	
A350*	LF2	0.30	0.60~1.35	0.035	0.040	0.15~0.30	MAX 0.40	MAX 0.30	MAX 0.12			70 ~ 95 (485 ~ 655)	36(250)	22	30	
A350*	LF3	0.20	MAX 0.90	0.035	0.040	0.20~0.35	3.3~3.7	MAX 0.30	MAX 0.12			70 ~ 95 (485 ~ 655)	37.5(260)	22	35	

*OTHER ELEMENTS : Copper(0.40% MAX), Vanadium(0.80% MAX), Columbium(0.20% MAX)

*The sum of Cu, Ni, Cr and Mo shall not be exceed 1.00%

*The sum of Cr and Mo shall not be exceed 0.32%

**A182F91 : Cb 0.06 ~ 0.10, N 0.03 ~ 0.07, Al 0.04, V 0.18 ~ 0.25

Wall Thickness of Welded and Seamless Pipe

Unit : mm

Nominal Pipe Size		Outside Diameter		Nominal Wall Thickness							
A	B	KS/JIS	ANSI	SPP SGP	Sch 5s	Sch 10s	Sch 10	Sch 20s	Sch 20	Sch 30	Sch 40s
6	1/8	10.50	10.29	-	-	1.24	-	1.5	-	-	1.73
8	1/4	13.80	13.72	-	-	1.65	-	2.0	-	-	2.24
10	3/8	17.30	17.14	-	-	1.65	-	2.0	-	-	2.31
15	1/2	21.70	21.34	2.8	1.65	2.11	-	2.5	-	-	2.77
20	3/4	27.20	26.67	2.8	1.65	2.11	-	2.5	-	-	2.87
25	1	34.00	33.40	3.2	1.65	2.77	-	3.0	-	-	3.38
32	1 1/4	42.70	42.16	3.5	1.65	2.77	-	3.0	-	-	3.56
40	1 1/2	48.60	48.26	3.5	1.65	2.77	-	3.2	-	-	3.68
50	2	60.50	60.32	3.8	1.65	2.77	-	3.5	3.20	-	3.91
65	2 1/2	76.30	73.02	4.2	2.11	3.05	-	3.5	4.50	-	5.16
80	3	89.10	88.90	4.2	2.11	3.05	-	4.0	4.50	-	5.49
90	3 1/2	101.60	101.60	4.2	2.11	3.05	-	4.0	4.50	-	5.74
100	4	114.30	114.30	4.5	2.11	3.05	-	4.0	4.90	-	6.02
125	5	139.80	141.30	4.5	2.77	3.40	-	5.0	5.10	-	6.55
150	6	165.20	168.30	5.0	2.77	3.40	-	5.0	5.50	-	7.11
200	8	216.30	219.08	5.8	2.77	3.76	-	6.5	6.35	7.04	8.18
250	10	267.40	273.05	6.6	3.40	4.19	-	6.5	6.35	7.80	9.27
300	12	318.50	323.80	6.9	3.96	4.57	-	6.5	6.35	8.38	9.52
350	14	355.60	355.60	7.9	3.96	4.78	6.35	8.0	7.92	9.52	*9.52
400	16	406.40	406.40	7.9	4.19	4.78	6.35	8.0	7.92	9.52	*9.52
450	18	457.20	457.20	7.9	4.19	4.78	6.35	8.0	7.92	11.12	*9.52
500	20	508.00	508.00	7.9	4.78	5.54	6.35	9.5	9.52	12.70	*9.52
550	22	558.80	558.80	-	4.78	5.54	6.35	-	9.52	12.70	*9.52
600	24	609.60	609.60	-	5.54	6.35	6.35	-	9.52	14.27	*9.52
650	26	660.40	660.40	-	-	*7.92	7.92	-	12.70	-	*9.52
700	28	711.20	711.20	-	-	*7.92	7.92	-	12.70	15.88	*9.52
750	30	762.00	762.00	-	6.35	*7.92	7.92	-	12.70	15.88	*9.52
800	32	812.80	812.80	-	-	*7.92	7.92	-	12.70	15.88	*9.52
850	34	863.60	863.60	-	-	*7.92	7.92	-	12.70	15.88	*9.52
900	36	914.40	914.40	-	-	*7.92	7.92	-	12.70	15.88	*9.52
950	38	965.20	965.20	-	-	*7.92	-	-	-	-	*9.52
1000	40	1016.00	1016.00	-	-	*7.92	-	-	-	-	*9.52
1050	42	1066.80	1066.80	-	-	*7.92	-	-	-	-	*9.52
1100	44	1117.60	1117.60	-	-	*7.92	-	-	-	-	*9.52
1150	46	1168.40	1168.40	-	-	*7.92	-	-	-	-	*9.52
1200	48	1219.20	1219.20	-	-	*7.92	-	-	-	-	*9.52

Asterisks(*) denote SUPERLOK Standards as no internationally Recognized Standards for these wallthickness have been established

Wall Thickness of Welded and Seamless Pipe

Unit : mm

Nominal Wall Thickness											Nominal Pipe Size Inch
STD	Sch 40	Sch 60	Sch 80s	X-S	Sch 80	Sch 100	Sch 120	Sch 140	Sch 160	XX-S	
1.73	1.73	2.20	2.41	2.41	2.41	-	-	-	3.15	4.83	1/8
2.24	2.24	2.40	3.02	3.02	3.02	-	-	-	3.68	6.05	1/4
2.31	2.31	2.80	3.20	3.20	3.20	-	-	-	4.01	6.40	3/8
2.77	2.77	3.20	3.73	3.73	3.73	-	-	-	4.78	7.47	1/2
2.87	2.87	3.40	3.91	3.91	3.91	-	-	-	5.56	7.82	3/4
3.38	3.38	3.90	4.55	4.55	4.55	-	-	-	6.35	9.09	1
3.56	3.56	4.50	4.85	4.85	4.85	-	-	-	6.35	9.70	1 1/4
3.68	3.68	4.50	5.08	5.08	5.08	-	-	-	7.14	10.16	1 1/2
3.91	3.91	4.90	5.54	5.54	5.54	-	-	-	8.74	11.07	2
5.16	5.16	6.00	7.01	7.01	7.01	-	-	-	9.52	14.02	2 1/2
5.49	5.49	6.60	7.62	7.62	7.62	-	-	-	11.12	15.24	3
5.74	5.74	7.00	8.08	8.08	8.08	-	-	-	-	-	3 1/2
6.02	6.02	7.10	8.56	8.56	8.56	-	11.12	-	13.49	17.12	4
6.55	6.55	8.10	9.53	9.53	9.53	-	12.70	-	15.88	19.05	5
7.11	7.11	9.30	10.97	10.97	10.97	-	14.27	-	18.26	21.94	6
8.18	8.18	10.31	12.70	12.70	12.70	15.09	18.26	20.62	23.01	22.22	8
9.27	9.27	12.70	12.70	12.70	15.09	18.26	21.44	25.40	28.58	25.40	10
9.52	10.31	14.27	12.70	12.70	17.48	21.44	25.40	28.58	33.32	25.40	12
9.52	11.13	15.09	*12.70	12.70	19.05	23.83	27.79	31.75	35.71	-	14
9.52	12.70	16.66	*12.70	12.70	21.44	26.19	30.96	36.52	40.49	-	16
9.52	14.27	19.05	*12.70	12.70	23.82	29.36	34.92	39.67	45.24	-	18
9.52	15.09	20.62	*12.70	12.70	26.19	32.54	38.10	44.45	50.01	-	20
9.52	-	22.22	*12.70	12.70	25.58	34.92	41.28	47.62	53.98	-	22
9.52	17.48	24.61	*12.70	12.70	30.96	38.89	46.02	52.37	59.54	-	24
9.52	-	-	*12.70	12.70	-	-	-	-	-	-	26
9.52	-	-	*12.70	12.70	-	-	-	-	-	-	28
9.52	-	-	*12.70	12.70	-	-	-	-	-	-	30
9.52	17.48	-	*12.70	12.70	-	-	-	-	-	-	32
9.52	17.48	-	*12.70	12.70	-	-	-	-	-	-	34
9.52	19.05	-	*12.70	12.70	-	-	-	-	-	-	36
9.52	-	-	*12.70	12.70	-	-	-	-	-	-	38
9.52	-	-	*12.70	12.70	-	-	-	-	-	-	40
9.52	-	-	*12.70	12.70	-	-	-	-	-	-	42
9.52	-	-	*12.70	12.70	-	-	-	-	-	-	44
9.52	-	-	*12.70	12.70	-	-	-	-	-	-	46
9.52	-	-	*12.70	12.70	-	-	-	-	-	-	48