



mixer cartridge seal
range

The AESSEAL[®] Group
of Companies

Designers and
Manufacturers of
Mechanical Seals and
Engineered Seal
Support Systems



Mixmaster Range of Cartridge seals for Mixers

This brochure covers the range of AESSEAL® Mixmaster mechanical seals designed for Mixers, Agitators and Reactors.

Mixer, Agitator and Reactor applications vary from simple blending or solid dissolution to the more exacting standards of solids suspension, gas dispersion or containing/promoting chemical reactions.

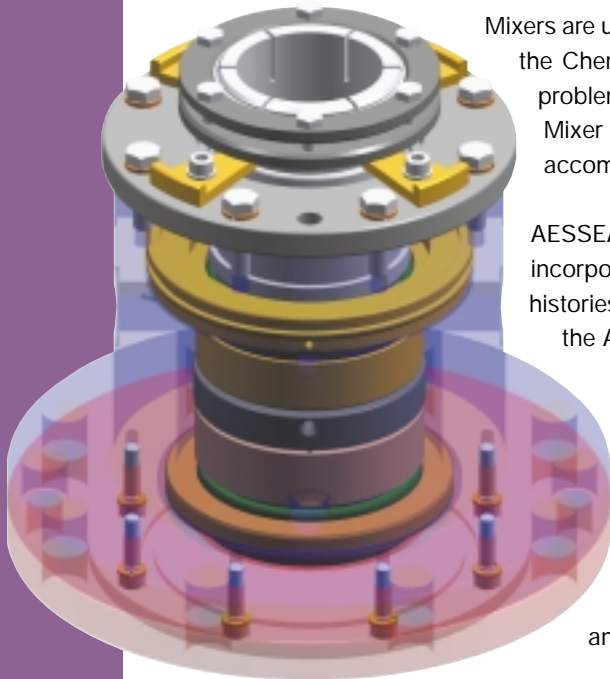

3D creation of a Mixmaster IV™ seal

Mixers are used in the Food, Beverage and Pharmaceutical industries, yet generally the Chemical and Process industries have the most varied and difficult mixer problems and therefore require precise sealing technology. The AESSEAL® Mixer seal range ensures that the most demanding applications can be accommodated.

AESSEAL® also produce a Mixer Agitator & Reactor Seal Range Booklet which incorporates more specialized seals for this industry as well as in depth case histories of seals. For more information this brochure can be downloaded from the AESSEAL® website at www.aesseal.com.

Development Background

The AESSEAL® Mixmaster range has been developed only after extensive performance and field evaluation tests, conducted over many years.

The range has been created using the latest Computer Aided Design and Manufacture programmes including Finite Element Analysis.

These programmes help to predict how the seals can be produced and also how they will perform under various application conditions. This technology has vastly reduced the lead time for product development and thus reduced the overall cost of the seal range.



Computer simulation is very effective for evaluating seal performance, however, all AESSEAL® mechanical seals still have to undergo physical testing in various hazardous conditions.

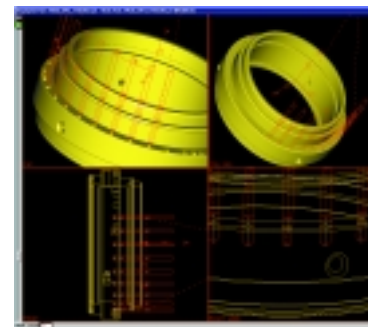

Integrated CAM programming

Massive investment in Computer Aided Design, Manufacture and PDM (Product Data Management) helps to ensure that the seal is fit for the purpose.



Investment in test facilities to suit API-682 allows computer controlled 24hr product testing for all AESSEAL® designs. The result is an industry leading range of mechanical seals.

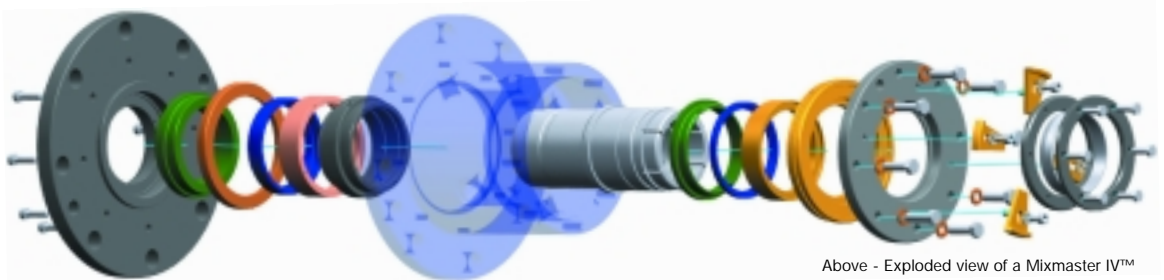

Above - Exploded view of a Mixmaster IV™

Mixmaster IV™



The seal range is offered with the following design features:

- Designed for mixers, agitators and reactors
- Double hydraulically balanced seal faces
- Available with non-metallic wetted components
- Cartridge seal with integral load carrying bearing to DIN 28 138 parts 1 and 2
- Available to suit any shaft (within the size range)
- No shaft fretting

Specifications Mixmaster IV™

The Mixmaster IV™ Range of Mixer Seals conform to the following relevant DIN Specifications.

- DIN 28 138 part 1 - Stainless Mixer Seal
- DIN 28 138 part 2 - Glass Lined
- DIN 28 138 part 3 - Screwed Connection
Designation & Position
- DIN 28 137 part 2 - Glass Lined Mounting Flanges
- DIN 28 141 - Stainless Steel Mounting Flanges
- DIN 28 154 & 159 - Shaft Dimensions



Environmental Connections

The Mixmaster IV™ connections are positioned in accordance with DIN 28 138 part 3.

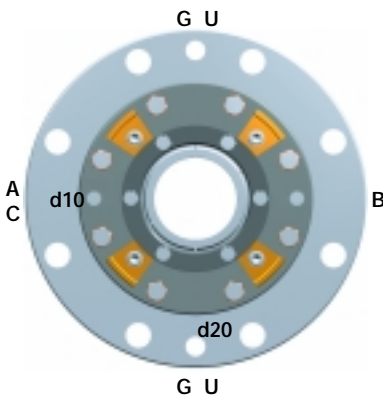

- A = Barrier IN
- B = Barrier OUT
- C = Leakage to Atmosphere
- G = Grease Port
- U = Pressure / Thermometer Port
- d10 = Lifting Threads
- d20 = Jacking Threads

MIXMASTER IV™ Load Carrying Capabilities			
ØD3	DIN 28 159 Max Loads		
	40mm (1.500")	1,562 N	351 lbs
50mm (2.000")	3,468 N	779 lbs	
60mm (2.375")	6,640 N	1492 lbs	
80mm (3.125")	17,289 N	3886 lbs	
100mm (4.000")	34,820 N	7827 lbs	
125mm (5.000")	44,188 N	9933 lbs	
140mm (5.500")	38,147 N	8575 lbs	
160mm (6.250")	60,185 N	13530 lbs	

AESSEAL® Code System for Mixmaster IV™ Seals

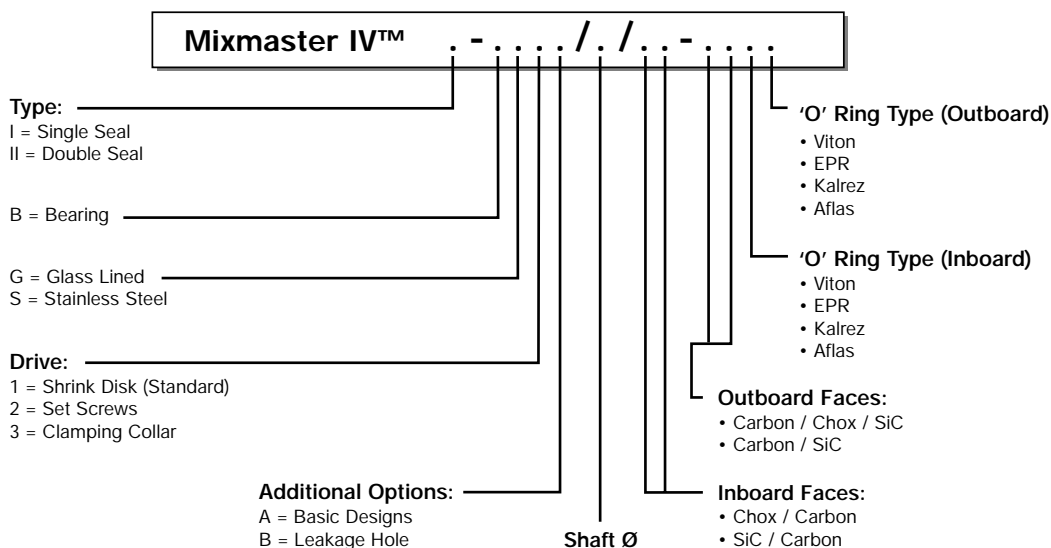



Mixmaster IV-II-BS™

The Mixmaster IV™ is a fully customizable top entry seal designed in accordance with DIN 28 138.

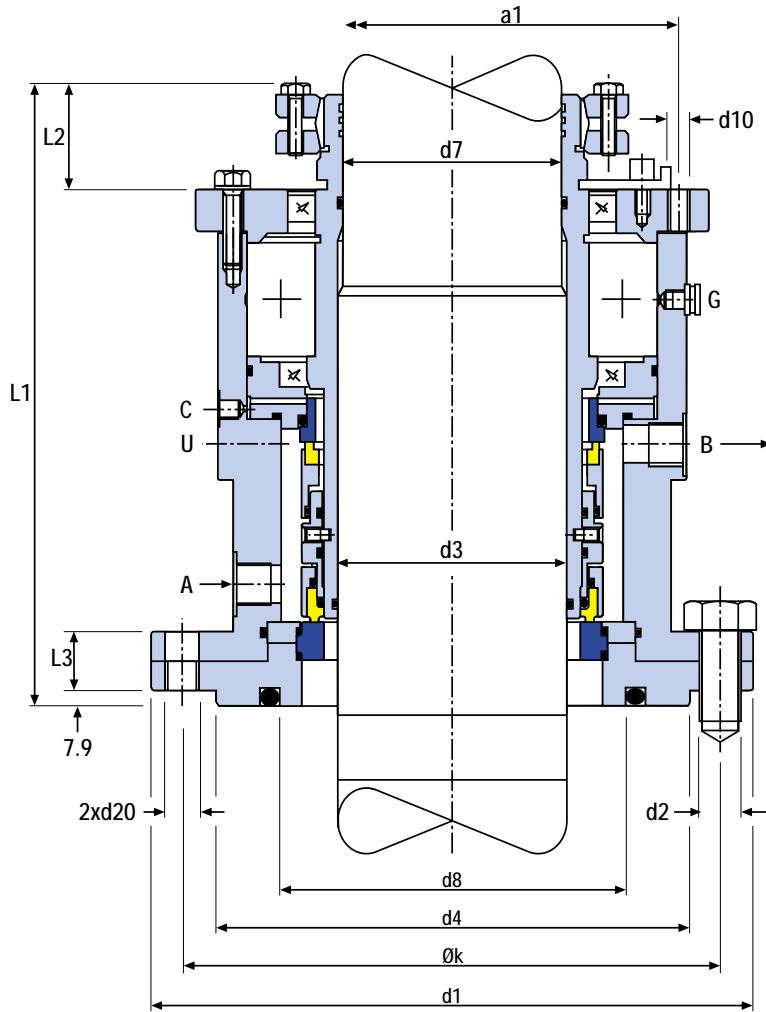

- Top entry seal design
- Double hydraulically balanced inboard seal faces
- Conforms to DIN 28 138 Part 1 and DIN 28 141
- Modular design
- Available to fit any shaft size within the seal range
- Connections positioned in accordance with DIN 28 138 Part 3
- Integral load carrying bearing
- Metallic wetted parts

Mixmaster IV-II-BS™ Size Chart (mm)

d3	d7	d1	nxd2	d4	d8	Øk	L1	L2	d10	d20	A,B	C	U	L3	a1
30, 33, 35, 38	-	175	4x18	110	95	145	210	33.5	M12	M16	G3/8	G1/8	G1/2	28	109.5
40	38	175	4x18	110	95	145	210	33.5	M12	M16	G3/8	G1/8	G1/2	28	109.5
43, 45, 48	-	240	8x18	176	107	210	215	33.5	M12	M16	G3/8	G1/8	G1/2	28	133
50	48	240	8x18	176	107	210	215	33.5	M12	M16	G3/8	G1/8	G1/2	28	133
53, 55, 58	-	240	8x18	176	121	210	225	33.5	M12	M16	G3/8	G1/8	G1/2	35	146
60	58	240	8x18	176	121	210	225	33.5	M12	M16	G3/8	G1/8	G1/2	35	146
63, 65, 68, 70, 75	-	275	8x22	204	150	240	265	45	M16	M20	G1/2	G1/8	G1/2	40	190
80	78	275	8x22	204	150	240	265	45	M16	M20	G1/2	G1/8	G1/2	40	190
85, 90, 95	-	305	8x22	234	174	270	270	45	M16	M20	G1/2	G1/8	G1/2	40	220
100	98	305	8x22	234	174	270	270	45	M16	M20	G1/2	G1/8	G1/2	40	220
105, 110, 115, 120	-	330	8x22	260	200	295	312	45	M20	M20	G1/2	G1/8	G1/2	40	249
125	120	330	8x22	260	200	295	312	45	M20	M20	G1/2	G1/8	G1/2	40	249
130, 135	-	395	12x22	313	219	350	318	52	M20	M20	G1/2	G1/8	G1/2	22	264
140	135	395	12x22	313	219	350	318	52	M20	M20	G1/2	G1/8	G1/2	22	264
145, 150, 155	-	395	12x22	313	219	350	318	52	M20	M20	G1/2	G1/8	G1/2	44	304
160	150	395	12x22	313	238	350	345	52	M20	M20	G1/2	G1/8	G1/2	44	304

Dimensional information on larger sizes is available on request.

Mixmaster IV-II-BS™ Size Chart (inches)

d3	d7	d1	nxd2	d4	d8	Øk	L1	L2	d10	d20	A,B	C	U
1.125" / 1.250" / 1.500"	-	6.890"	4 x 0.750"	4.330"	3.740"	5.710"	8.270"	1.320"	M12	M16	G3/8"	G1/8"	G1/2"
1.750" / 2.000" / 2.250"	-	9.450"	8 x 0.750"	6.930"	4.210"	8.260"	8.860"	1.320"	M12	M16	G3/8"	G1/8"	G1/2"
2.500" / 2.750" / 3.000"	-	10.830"	8 x 0.875"	8.030"	5.910"	9.450"	10.450"	1.770"	M16	M20	G1/2"	G1/8"	G1/2"
3.250" / 3.500" / 3.750" / 4.000"	-	12.000"	8 x 0.875"	9.210"	6.850"	10.630"	10.700"	1.770"	M16	M20	G1/2"	G1/8"	G1/2"
4.250" / 4.500" / 4.750" / 5.000"	-	13.000"	8 x 0.875"	10.240"	7.870"	11.610"	12.300"	1.770"	M20	M20	G1/2"	G1/8"	G1/2"
5.250" / 5.500"	-	15.550"	12 x 0.875"	12.320"	8.620"	13.780"	12.520"	2.050"	M20	M20	G1/2"	G1/8"	G1/2"
5.750" / 6.000" / 6.250"	-	15.550"	12 x 0.875"	12.320"	9.370"	13.780"	13.600"	2.050"	M20	M20	G1/2"	G1/8"	G1/2"

Dimensional information on larger sizes is available on request.

Mixmaster IV-II-BG™ Glass (Enamel) Lined



- Top entry seal design
- All wetted parts are non-metallic
- Double hydraulically balanced inboard seal faces
- Conforms to DIN 28 138 Part 2 and DIN 28 137 Part 2
- Modular design
- Available to fit any shaft size with the seal range
- Connections positioned in accordance with DIN 28 138 Part 3
- Designed to order with exotic alloy wetted materials including Alloy C276/Titanium/Alloy 20
- The flange can be designed to suit customer specific equipment

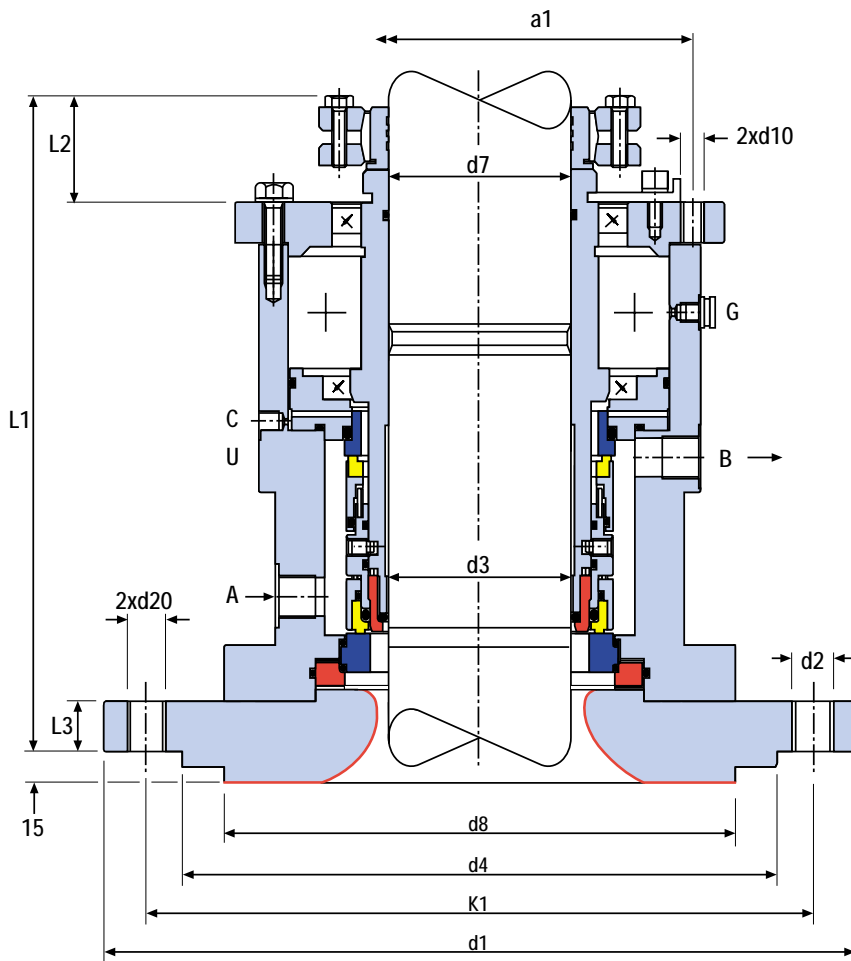

Flanges Nominal Diameters E700-E901

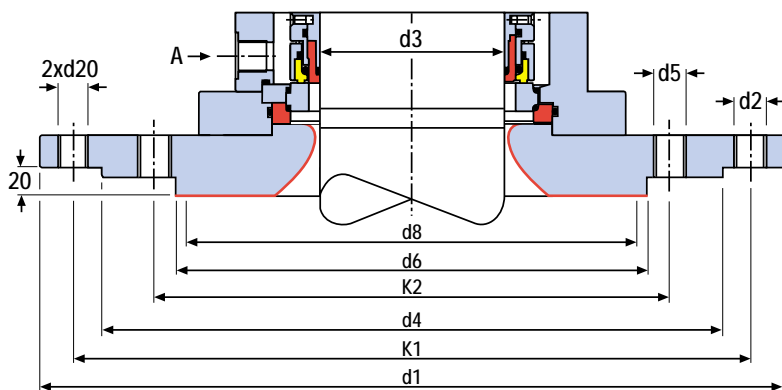

Mixmaster IV-II-BG™ Size Chart (mm)

d3	d7	d1	nx d2	d4	nx d5	d6	d8	d10	d20	a1	L1	K1	K2	L3	L2	A,B	C	U	NFD
40	38	175	4x18	110	-	-	138	M12	M16	110	226	145	-	20	33.5	G3/8	G1/8	G1/2	E125
50	48	240	8x18	176	-	-	138	M12	M16	133	226	210	-	20	33.5	G3/8	G1/8	G1/2	E200
60	58	275	8x22	204	-	-	188	M12	M16	146	234	240	-	22	33.5	G3/8	G1/8	G1/2	E250
80	78	305	8x22	234	-	-	212	M16	M20	190	275	270	-	25	45	G1/2	G1/8	G1/2	E300
100	98	395	12x22	313	-	-	268	M16	M20	200	282	350	-	25	45	G1/2	G1/8	G1/2	E500
125	120	505	4x22	422	12x22	320	306	M20	M20	249	323	460	350	22	52	G1/2	G1/8	G1/2	E700
140	135	505	4x22	422	12x22	320	306	M20	M20	264	331	460	350	22	52	G1/2	G1/8	G1/2	E700
160	150	505	4x22	422	12x22	320	306	M20	M20	304	355	460	350	22	52	G1/2	G1/8	G1/2	E900
160*	150	565	4x26	474	12x22	370	356	M20	M20	304	355	515	400	22	52	G1/2	G1/8	G1/2	E901

Dimensional information on larger sizes is available on request.

* Nominal size 161



Mixmaster V™ - internal balanced mechanical seal

The Mixmaster V™ is a value for money, modular design with balanced seal faces and an integral load carrying bearing. The seal is designed in accordance with DIN 28 138. The Mixmaster V™ is a standard design which can not be customized.

The seal is offered with the following features:

- Top entry seal design
- Designed for mixers, agitators and reactors
- Balanced seal faces for the barrier fluid (Mixmaster V™)
- Cartridge seal with integral load carrying bearing to DIN 28 159
- No shaft fretting
- Modular design
- Seal faces remain closed in reverse pressure conditions

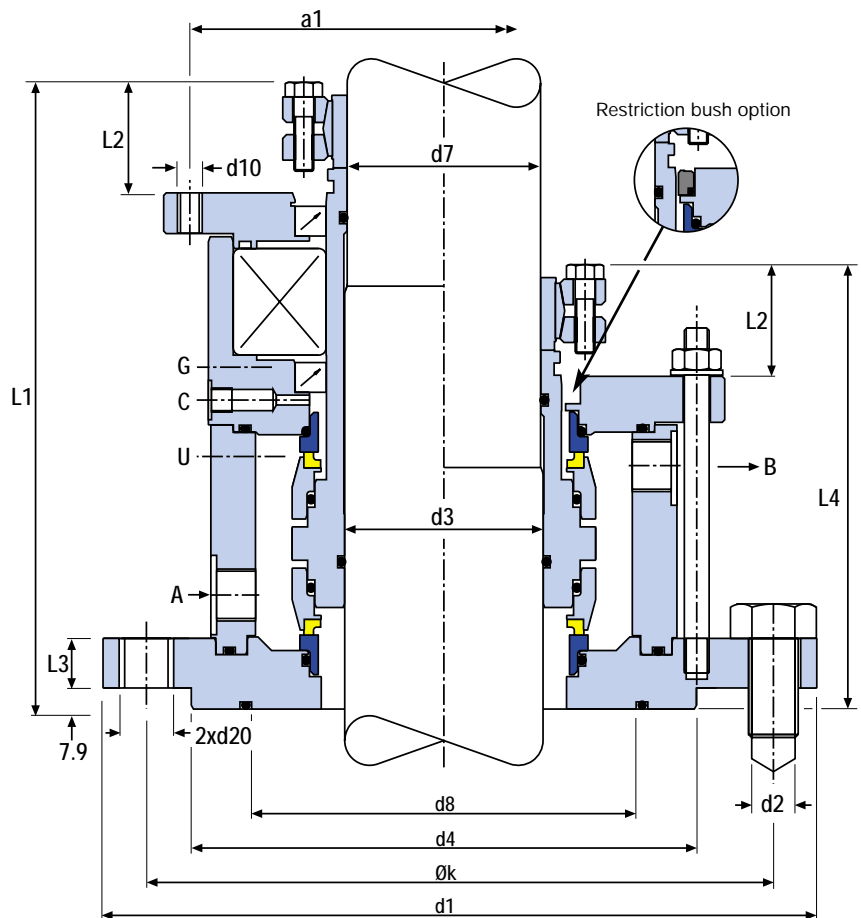

NOTE: The mounting flange is designed to DIN 28 138

Mixmaster V-II-BS™ Size Chart (mm)

d3	d7	d1	nxd2	d4	d8	Øk	L1	L2	d10	d20	A,B	C	U	L3	L4	a1
40	38	175	4x18	110	92	145	204	32	M12	M16	G3/8	G1/8	G1/2	15	149	132
50	48	240	8x18	176	136	210	213	32	M12	M16	G3/8	G1/8	G1/2	17	152	155
60	58	240	8x18	176	140	210	217	32	M12	M16	G3/8	G1/8	G1/2	17	155	164
80	78	275	8x22	204	155	240	253	45	M16	M20	G1/2	G1/8	G1/2	20	179	204
100	98	305	8x22	234	187	270	256	45	M16	M20	G1/2	G1/8	G1/2	20	179	215
125	120	330	8x22	260	213	295	293	46	M20	M20	G1/2	G1/8	G1/2	20	200	275
140	135	395	12x22	313	251	350	306	46	M20	M20	G1/2	G1/8	G1/2	20	208	285

Dimensional information on larger sizes is available on request.

The seal range is also available without the bearing assembly, as shown on the right hand side of the above diagram.

A single seal option which includes the bearing is available on request.

Mixmaster VI™



The Mixmaster VI™ uses the modular components of the Mixmaster V™ and incorporates double balanced seal faces. The seal is designed in accordance with DIN 28 138. The Mixmaster VI™ is a standard design which can only be customized in 3 ways: 1 - thick sleeve, 2 - flange modification, 3 - exotic alloy wetted components. For any other modifications refer to the Mixmaster IV™ design.

The seal is offered with the following features:

- Top entry seal design
- Designed for mixers, agitators and reactors
- Double balanced inboard seal faces (Mixmaster VI™)
- Cartridge seal with integral load carrying bearing to DIN 28 159
- No shaft fretting
- Modular design

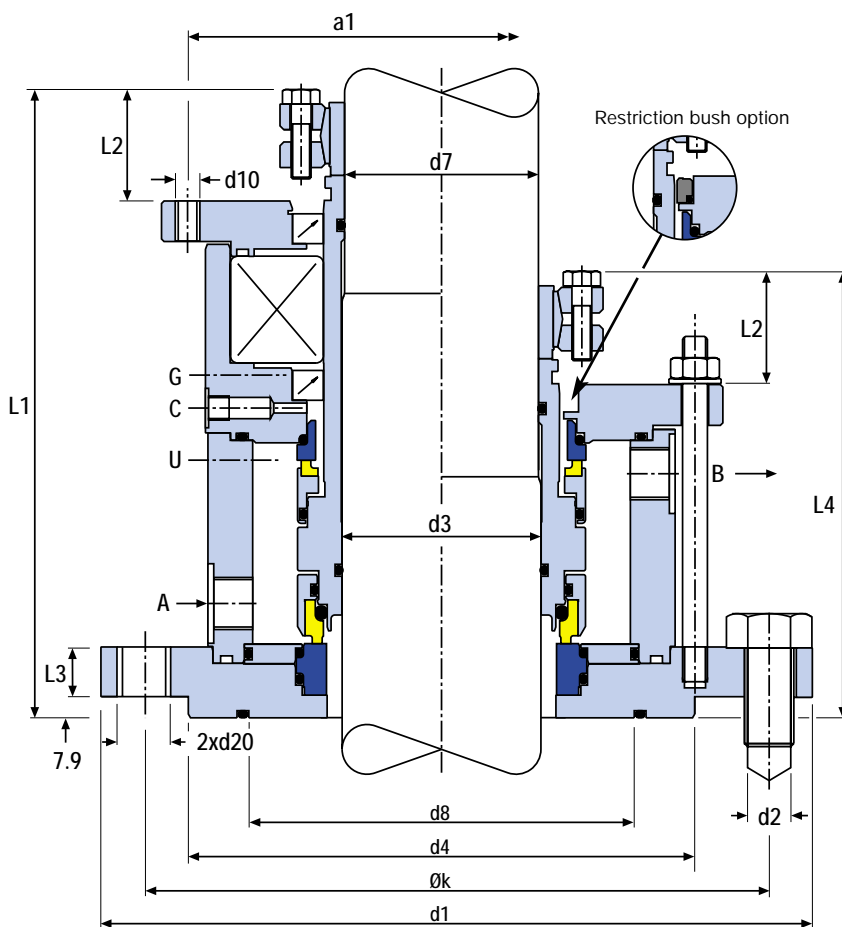

NOTE: The mounting flange can be supplied to suit customer equipment

Mixmaster VI-II-BS™ Size Chart (mm)

d3	d7	d1	nxd2	d4	d8	Øk	L1	L2	d10	d20	A,B	C	U	L3	L4	a1
40	38	175	4x18	110	92	145	204	32	M12	M16	G3/8	G1/8	G1/2	15	149	132
50	48	240	8x18	176	136	210	213	32	M12	M16	G3/8	G1/8	G1/2	17	152	155
60	58	240	8x18	176	140	210	217	32	M12	M16	G3/8	G1/8	G1/2	17	155	164
80	78	275	8x22	204	155	240	253	45	M16	M20	G1/2	G1/8	G1/2	20	179	204
100	98	305	8x22	234	187	270	256	45	M16	M20	G1/2	G1/8	G1/2	20	179	215
125	120	330	8x22	260	213	295	293	46	M20	M20	G1/2	G1/8	G1/2	20	200	275
140	135	395	12x22	313	251	350	306	46	M20	M20	G1/2	G1/8	G1/2	20	208	285

Dimensional information on larger sizes is available on request.

The seal range is also available without the bearing assembly, as shown on the right hand side of the above diagram.

A single seal option which includes the bearing is available on request.

Mixmaster VI™ - flange options

Extensive design modularity has been incorporated into the standard Mixmaster VI™ range. In addition to the standard stainless steel flange design, AESSEAL® offer FOUR further alternates as shown below.

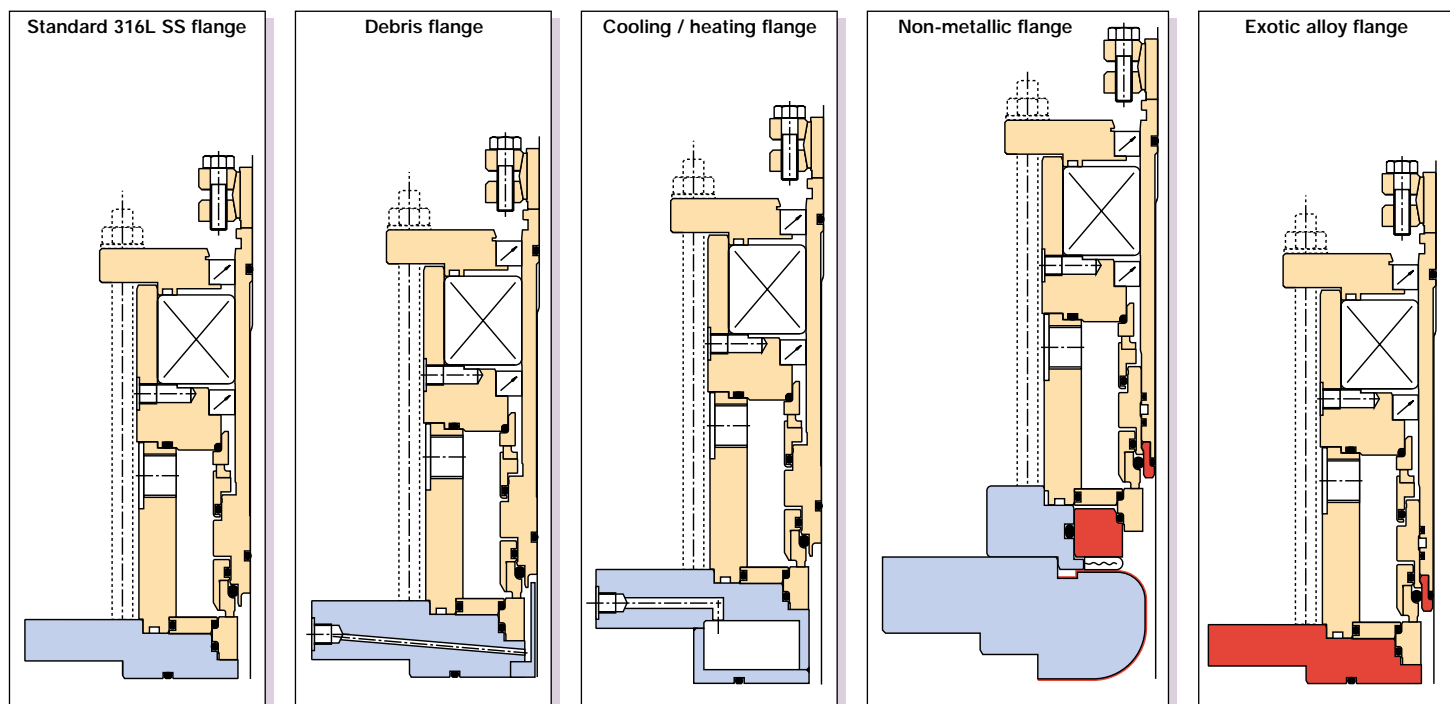

Debris Flange

In some applications, particularly in the food or pharmaceutical industries, an in-place cleaning operation such as CIP is required.

In addition to this, often on vertical applications, carbon seal face debris is not permitted to enter the process media.

The Debris Flange with optional deflector arrangement is offered to facilitate such process requirements.

Cooling / Heating Flange

Changing the seal environment is often key when sealing difficult applications.

The Cooling / Heating flange option allows the temperature at the seal faces to be controlled, thereby helping to extend seal life in some difficult thermal applications.

Non-Metallic Flange

To complement the non-metallic product offering, AESSEAL® offer inventoried enamel flanges, conforming to DIN 28-137 part 2.

The Mixmaster VI™ non-metallic design also allows the cartridge seal to be removed and replaced without disturbing the enamelled flange.

Exotic Alloy Flange

The standard Mixmaster VI™ Exotic flange option is designed to DIN 28-141 and offered in any commercially available material including Alloy C276 and Titanium.

While some DIN style Stainless Steel, Enamel and Exotic flanges are inventoried, most flanges are made to suit customer requirements.

THIS DOCUMENT IS DESIGNED TO PROVIDE DIMENSIONAL INFORMATION AND AN INDICATION OF AVAILABILITY. FOR FURTHER INFORMATION AND SAFE OPERATING LIMITS CONTACT OUR TECHNICAL SPECIALISTS AT THE LOCATIONS BELOW.



USE DOUBLE MECHANICAL SEALS WITH HAZARDOUS PRODUCTS. ALWAYS TAKE SAFETY PRECAUTIONS:

- GUARD YOUR EQUIPMENT
- WEAR PROTECTIVE CLOTHING



AESSEAL plc
Mill Close
Templeborough
Rotherham
S60 1BZ
United Kingdom

Telephone:
Fax:
E-mail:
Internet:

WINNER OF THE
NATWEST
SUNDAY TIMES
COMPANY OF
TOMORROW
AWARD

+44 (0) 1709 369966
+44 (0) 1709 720788
seals@aes seal.com
<http://www.aes seal.com>

Distributed by:

USA Sales & Technical advice:
AESSEAL Inc.
10231 Cogdill Road
Suite 105
Knoxville, TN 37932
USA
Telephone: 865 531 0192
Fax: 865 531 0571

ALL SIZES ARE SUBJECT TO MANUFACTURING TOLERANCES. WE RESERVE THE RIGHT TO MODIFY SPECIFICATIONS AT ANY TIME.